











**MATRIX**  
mechatronics

HIGH PERFORMANCE  
INDIVIDUAL AND MULTI-VALVES

## SOLENOID VALVES

<p>Micro valve</p> <p>Series <b>320</b></p> <p>Page 6</p>		<p>Function 2/2 • 3/2</p> <p>Voltage 6/12/24 VDC; Speed-Up!</p> <p>Flow rate 30 l/min.</p> <p>Pressure range 0-8 bar; Vacuum 10<sup>-5</sup> Torr</p>	<p>Dimensions 8 x 23 x 24.5 mm</p> <p>Weight 9 g</p>
<p>Multi-valve</p> <p>Series <b>580</b></p> <p>Page 10</p>		<p>Function 2/2</p> <p>Voltage Speed-Up!</p> <p>Flow rate 180 l/min.</p> <p>Pressure range 0-5 bar</p>	<p>Dimensions 28 x 100 x 49.6 mm</p> <p>Weight 400 g</p>
<p>Individual valve</p> <p>Series <b>720</b></p> <p>Page 14</p>		<p>Function 2/2 • 3/2</p> <p>Voltage 12 VDC; 24 VDC; Speed-Up!</p> <p>Flow rate 50-100 l/min.</p> <p>Pressure range 0-8 bar; Vacuum 10<sup>-5</sup> Torr</p>	<p>Dimensions 12 x 41 x 39.5 mm</p> <p>Weight 35 g</p>
<p>Multi-valve</p> <p>Series <b>750</b></p> <p>Page 18</p>		<p>Function 2/2 • 3/2 • 3/3 • 5/2</p> <p>Voltage 12 VDC; 24 VDC; Speed-Up!</p> <p>Flow rate 50-700 l/min.</p> <p>Pressure range 0-8 bar; Vacuum 10<sup>-5</sup> Torr</p>	<p>Dimensions 55 x 55 x 48 mm</p> <p>Weight 350 g</p>
<p>Individual valve</p> <p>Series <b>820</b></p> <p>Page 30</p>		<p>Function 2/2 • 3/3</p> <p>Voltage 24 VDC; Speed-Up!</p> <p>Flow rate 100-220 l/min.</p> <p>Pressure range 0-8 bar</p>	<p>Dimensions 12 x 37 x 28.5 mm</p> <p>Weight 25 g</p>
<p>Individual valve</p> <p>Series <b>820</b> ISD</p> <p>Page 34</p>		<p>Function 2/2</p> <p>Voltage 24 VDC</p> <p>Flow rate 100-180 l/min.</p> <p>Pressure range 2-8 bar</p>	<p>Dimensions 12 x 37 x 53.5 mm</p> <p>Weight 25 g</p>
<p>Multi-valve</p> <p>Series <b>860</b></p> <p>Page 38</p>		<p>Function 2/2</p> <p>Voltage Speed-Up!</p> <p>Flow rate 1-750 l/min.</p> <p>Pressure range 0-6 bar</p>	<p>Dimensions 52 x 52 x 55 mm</p> <p>Weight 450 g</p>
<p>Multi-valve</p> <p>Series <b>880</b></p> <p>Page 42</p>		<p>Function 2/2</p> <p>Voltage 24 VDC; 24/5 VDC Speed-Up!</p> <p>Flow rate 300-430 l/min.</p> <p>Pressure range 0-8 bar</p>	<p>Dimensions 12 x 75 x 41 mm</p> <p>Weight 72 g</p>
<p>Multi-valve</p> <p>Series <b>890</b></p> <p>Page 46</p>		<p>Function 2/2</p> <p>Voltage 24 VDC; Speed-Up!</p> <p>Flow rate 100-1620 l/min.</p> <p>Pressure range 0-8 bar</p>	<p>Dimensions 46 x 46 x 41.5 mm</p> <p>Weight 160 g</p>

## ELECTRONIC PRESSURE REGULATORS

Pressure regulator  
**Series EPR 100**  
Page 52



Regulating range 0-7 bar  
Flow rate 80 l/min.  
Input signal 0-5 V; 0-10 V; 4-20 mA;  
RS232 keypad

Dimensions 118 x 70 x 40 mm  
Weight 400 g

Pressure regulator  
**Series EPR 200/300/500**  
Page 52



Regulating range 0-7 bar  
Flow rate max. 500 l/min.  
Input signal 0-5 V; 0-10 V; 4-20 mA;  
RS232 keypad

Dimensions 60 x 60 x 97 mm  
Weight 500 g

Pressure regulator  
**Series SPR 700**  
Page 53



Regulating range 0-10 bar  
Flow rate 1,000 l/min.  
Input signal 0-5 V; 0-10 V; 4-20 mA;  
RS232 keypad

Dimensions 60 x 60 x 131 mm  
Weight 450 g

Pressure regulator  
**Series SPR 900**  
Page 53



Regulating range 0-10 bar  
Flow rate 4,000 l/min.  
Input signal 0-5V; 0-10V; 4-20mA;  
RS232 keypad

Dimensions 62 x 62 x 158 mm  
Weight 950 g

Pressure regulator  
**Series SPR 1000**  
Page 53



Regulating range 0-7 / 0-12 / 8-14 bar  
Flow rate 5,000 l/min.  
Input signal 0-5 V; 0-10 V; 4-20 mA;  
RS232 keypad

Dimensions 70 x 100 x 256 mm  
Weight 1,300 g

## SPECIAL SOLUTIONS

Special parts  
**Individual**  
from page 54

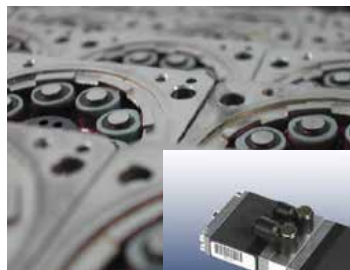

## PRODUCT DESCRIPTION

First of all it must be noted, that despite their particular features all MATRIX valves are suitable for any industrial application of pneumatic systems, and therefore can also be used for the simplest of tasks.

MATRIX valves have a unique and innovative technology. The switching operation takes place without friction and with very low masses (Fig.1). This technique enables a service life of **up to 4 billion (!)** switching operations and consequently reduces the maintenance intervals and operating costs of a plant enormously. The very high repeat accuracy over the entire service life and the reliability ensure constant quality and productivity. The frictionless mechanism enables extremely fast switching times of  $< 1$  ms for the complete switching operation (!) as well as a frequency of up to 1,500 Hz.

The modular design of the multi-valves (Fig. 2) enables the arrangement of multiple valves in a very tight space. Consequently up to 9 valves are arranged in one valve block of just 46 x 46 x 42 mm. This constellation saves the piping of the individual valves, which in turn saves material, installation space and working time and therefore simplifies the entire pneumatic system.

In summary, the MATRIX valve technology enables completely new methods and approaches in pneumatics.

MATRIX valves are insensitive to vibration and acceleration.

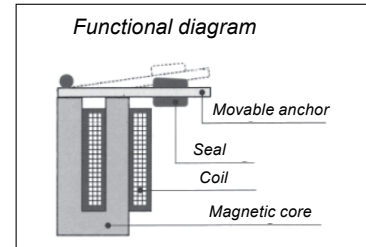

Fig. 1

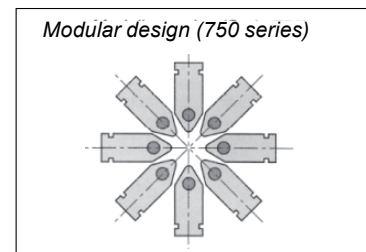

Fig. 2

## Typical features of the MATRIX valves

To simplify the decision for a MATRIX valve, one can check the following basic requirements, which speak in particular in favour of this valve technique:

- reliability and long service life (> 500 millions cycles)
- very good reproducibility over the entire service life
- fast switching times
- high frequencies
- frequency control (PWM – PFM)
- proportional flow rate
- compact design
- low weight
- multifunctionality (multiple functions per valve unit)
- customer-specific adaptations

## Typical fields of application

- Medical technology & biotechnology
- Handling & robotics
- Regulation of vacuum
- Packaging industry
- Marking systems
- Sorting & recycling (up to 1,500 Hz)
- Regulation of pneumatic drives
- Proportional regulation of flow rates
- Textile industry
- Plant engineering

# TECHNICAL INFORMATION

The valves can be controlled directly (ON/OFF) and with the following modulation:

- **PWM / Pulse-Width-Modulation** (Fig. 3)
- **PFM / Pulse-Frequency-Modulation** (Fig. 4)
- **PNM / Pulse-Number-Modulation** (Fig. 5)
- **PCM / Pulse-Code-Modulation** (Fig. 6)

A combination of modulations is also possible. This enables a wide range of the layout in the respective applications. A linear and/or proportional flow control is also possible. In the example of the 860 series valve, with the PCM control 256 flow rate levels can be called or set within 1 ms.

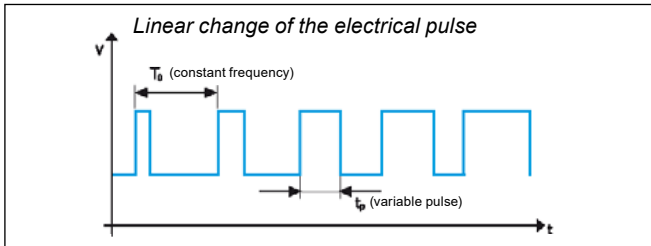

Fig. 3

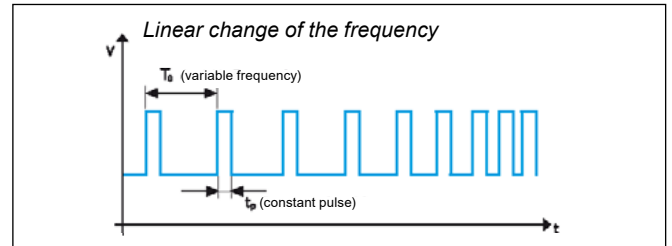

Fig. 4

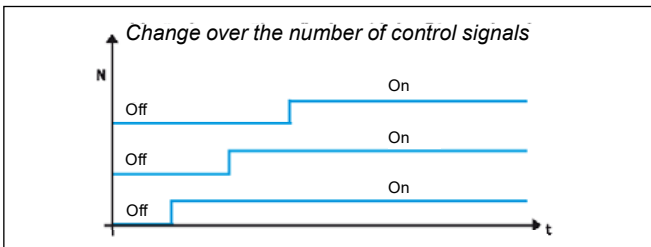

Fig. 5

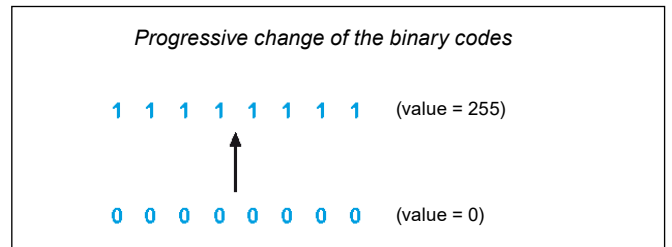

Fig. 6



## High energy efficiency in the Speed-Up version

The Speed-Up technology of MATRIX requires 100% output from the control system merely in the opening phase and this is then reduced to a holding level after < 5 ms (Fig. 7). This saves > 90% of the energy costs and at the same time reduces the development of heat.

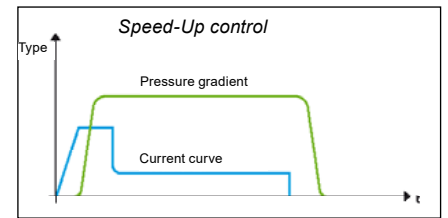

Fig. 7

## Medium

Compressed air quality of class 3 according to DIN ISO 8573-1 is required for fault-free functionality. The minimum requirement for our MATRIX valves are the classes 3/4/5 (see table).

Class	Oil content	Particles		Water content	
	mg/m <sup>3</sup>	Mm	mg/m <sup>3</sup>	DTP	g/m <sup>3</sup>
1	0.01	0.1	0.1	-70	0.003
2	0.1	1	1	-40	0.12
3	1	5	5	-20	0.88
4	5	15	8	3	6
5	25	40	10	7	7.8
6	--	--	--	10	9.4

Specification of the air quality when using the MATRIX valve series. Special valves and/or special applications may vary.

Media compatibility of the MATRIX valves and pressure regulators



Medium: Dry, non-lubricated air and neutral gases  
Filter mesh size: min. 40 microns (μ)  
Ambient temperature: -10° to + 50 °C

Sealing materials and temperature range

NBR: -10° to + 50 °C (standard)  
HNBR: -10° to + 80 °C (option, not for all series)  
FKM: -10° to + 80 °C (option, not for all series)  
With the optional sealing materials only the rocker seals are affected."

All flow rate values of the valves refer to 6 bar relative overpressure and unresisted flow.

## 320 SERIES

Greatest efficiency in the smallest design – this describes the 320 series valve in just a few words.

The current trend is towards a drastic reduction of the dimensions, the weight and the energy requirement with increasing performance and service life at the same time.

The unique mechanism of the MATRIX valves enables maximum performances among the micro pneumatic valves. The valve has a power consumption of just 0.05 A. Once again it is evident, what efficiency this valve technology achieves.

The very small size of 8 x 23 x 28 mm combines a 2/2 and 3/2 function in NC or NO and can be used as individual or manifold mounted valve. Consequently the 320 series valve can be used for multiple functions.

Despite the narrow structural width a flow rate of 30 l/min. is achieved. In addition to this is the low weight of 9g, which represents an enormous advantage in applications with high acceleration and movement.

The low power consumption saves operating costs and permits smaller controls. Versatile functions enable an optimised inventory, the low mass preserves resources and the limited thermal radiation saves constructive interventions. A further aspect is the extremely long service life, which reduces the LCC costs (Life Cycle Costs) to a minimum.



### Technical data

Switching time opening*	6/12/24 V: <3 ms	KK: <1.5 ms
Switching time closing*	6/12/24 V: <1.5 ms	KK: <1.5 ms
Maximum frequency	200 Hz	300 Hz
Weight	9 g	
Protection class	IP52	

\*Varies with the working pressure

Outlets	1
Flow rate	30 l/min.
Function	2/2 and 3/2 way in NC or NO
Pressure range	0-8 bar or vacuum

### Possible functions

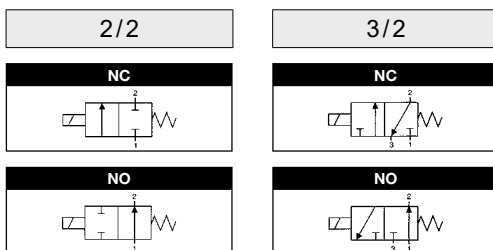

### Possible controls

Direct / PWM / PFM  
Information see page 5

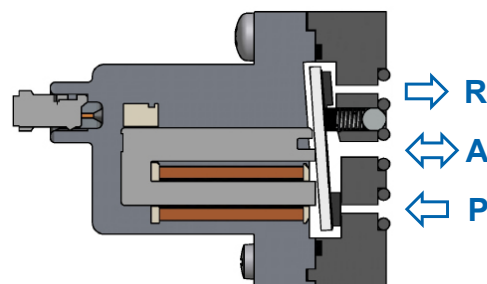

Section: Type 3/2 NC

Ordering code

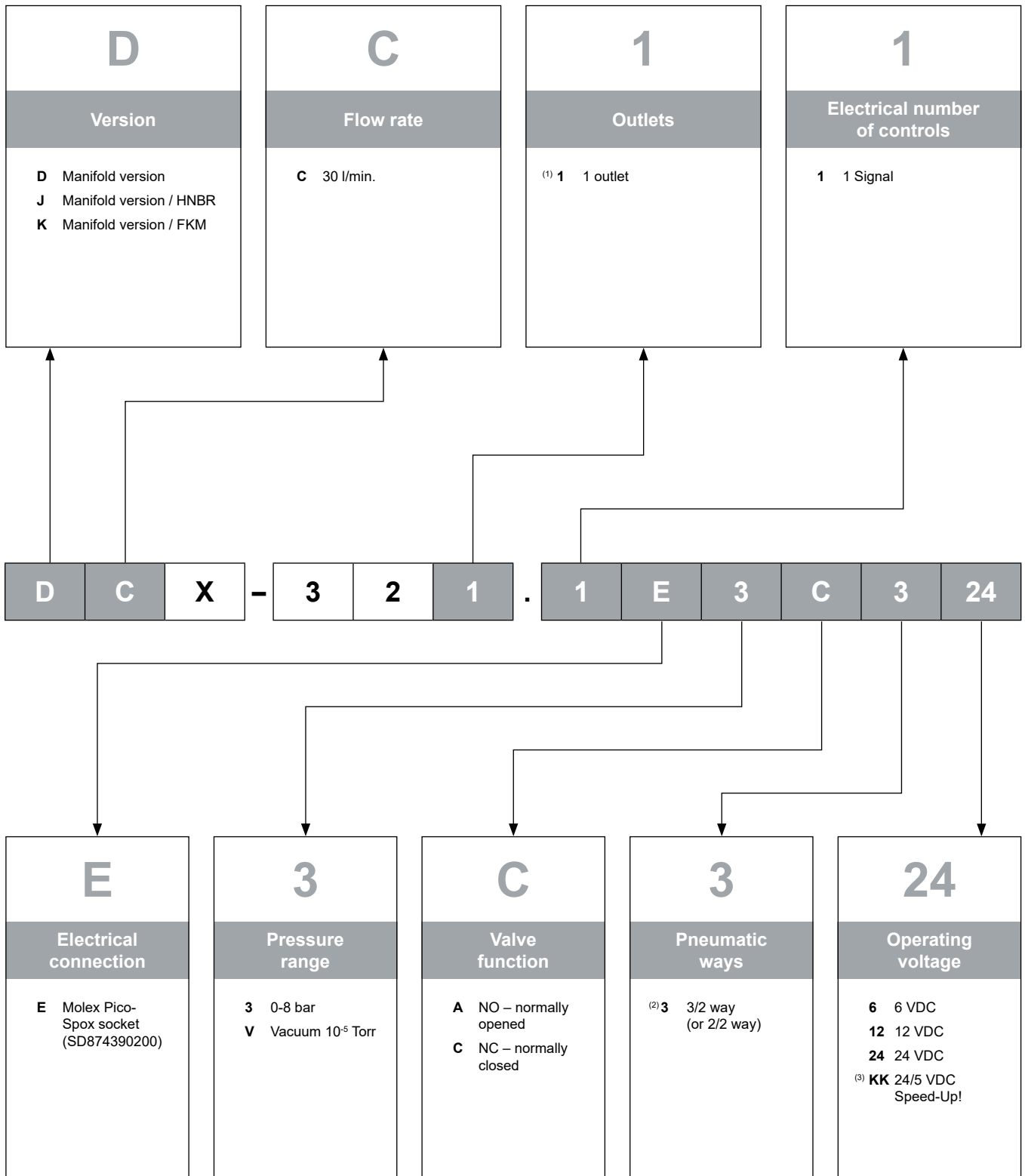

(1) without thread and plug-in connections  
 (2) according to the manifold the valve can also be used as 2/2 way  
 (3) requires a Speed-Up! Control (see intro pages)



# 320 SERIES

## Drawings and connections

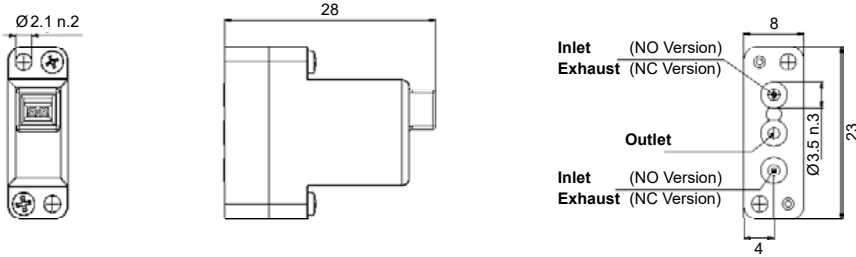

## Accessories

### Single manifolds for 2/2 function

Connection	Article code
Push-in fitting	<b>021.284Q</b>

### Single manifolds for 3/2 function

Connection	Article code
Push-in fitting	<b>021.244C</b>
Bushing	<b>021.333N</b>
Bushing with assembly plate	<b>021.350E</b>

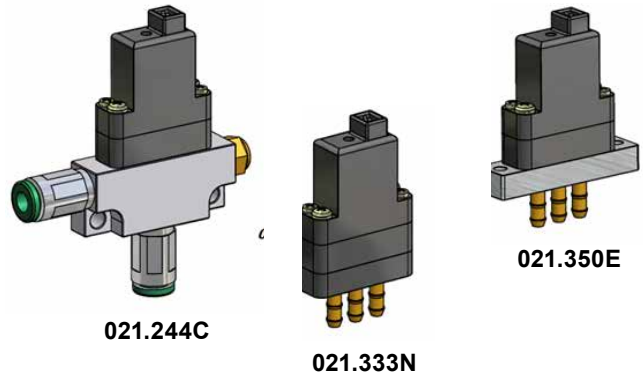

### Multiple manifolds for 2/2 function

Number of seats	Article code	Dimensions	
		Y	Z
For 2 valves	<b>021.353H</b>	31 mm	21 mm
For 4 valves	<b>021.354I</b>	49 mm	39 mm
For 6 valves	<b>021.355J</b>	67 mm	57 mm
For 8 valves	<b>021.357L</b>	85 mm	75 mm
For 10 valves	<b>021.288U</b>	103 mm	93 mm

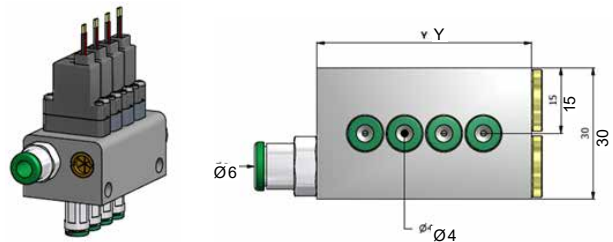

### Multiple manifolds for 3/2 function

Number of seats	Article code	Dimensions	
		Y	Z
For 2 valves	<b>021.352G</b>	31 mm	21 mm
For 4 valves	<b>021.265X</b>	49 mm	39 mm
For 6 valves	<b>021.266Y</b>	67 mm	57 mm
For 8 valves	<b>021.356K</b>	85 mm	75 mm
For 10 valves	<b>021.267Z</b>	103 mm	93 mm
For 16 valves	<b>021.274G</b>	157 mm	147 mm
For 32 valves	<b>021.299F</b>	331 mm	321 mm

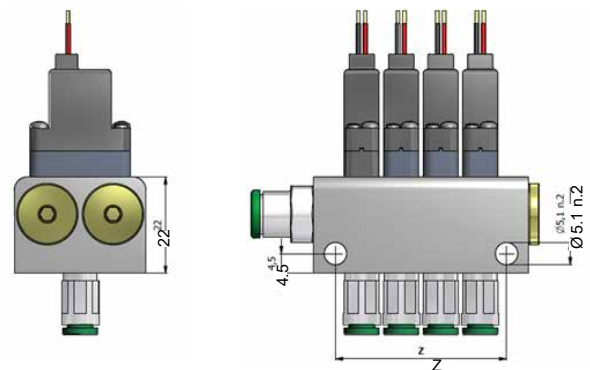

**Note:** All manifolds include mounting screws for the valves and screw connections.

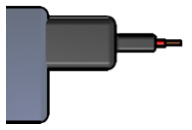

Valve cable AWG 28 / IP52

<b>Length</b>		with cap
500 mm		<b>021.260S</b>
2000 mm		<b>021.228M</b>
5000 mm		<b>021.484I</b>

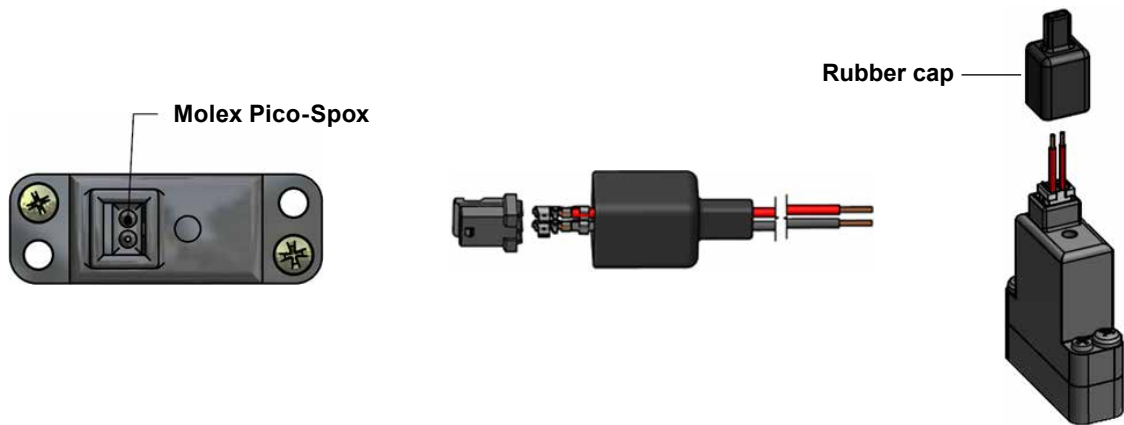

Product examples and special solutions

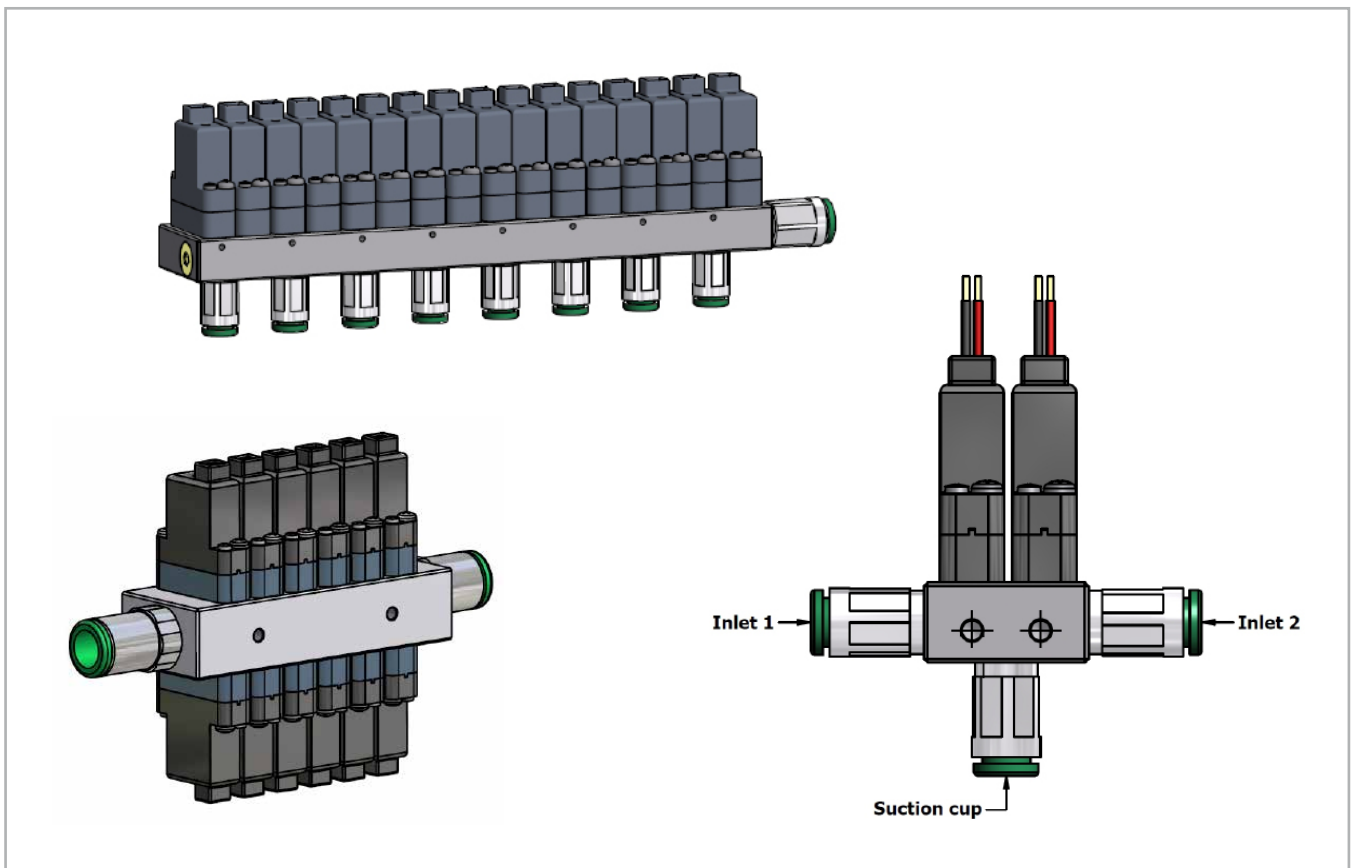

## 580 SERIES

With MATRIX, multi-valves, in other words a combination of multiple valves in one main body, are normally arranged in a circle. With the 580 series one has implemented a further concept, in order to enable a linear arrangement.

The 580 series valve combines 8 individual valves, whose outlets can be fitted with screw connections or a nozzle attachment. Mounting on a manifold is also possible.

Designed for a high flow rate, this valve is only available in the Speed-Up version.

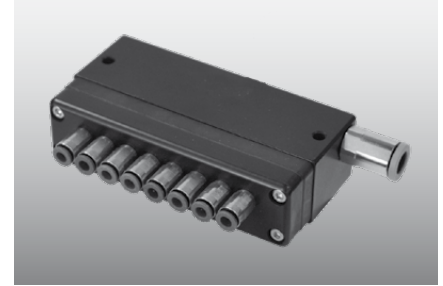

### Technical data

Switching time opening*	KK: <2 ms
Switching time closing*	KK: <2 ms
Maximum frequency	200 Hz
Weight	400 g
Protection class	IP62

\*Varies with the working pressure

Outlets	8
Flow rate	8x 135 l/min.
Function	2/2 way in NC
Pressure range	0-5 bar

### Possible function

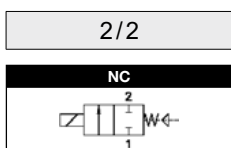

### Possible controls

**Direct / PWM / PFM / PNM / Combination**

*Information, see Page 5*

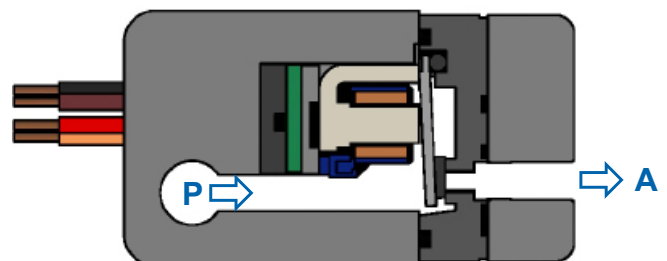

Section: Type 2/2 NC

Ordering code

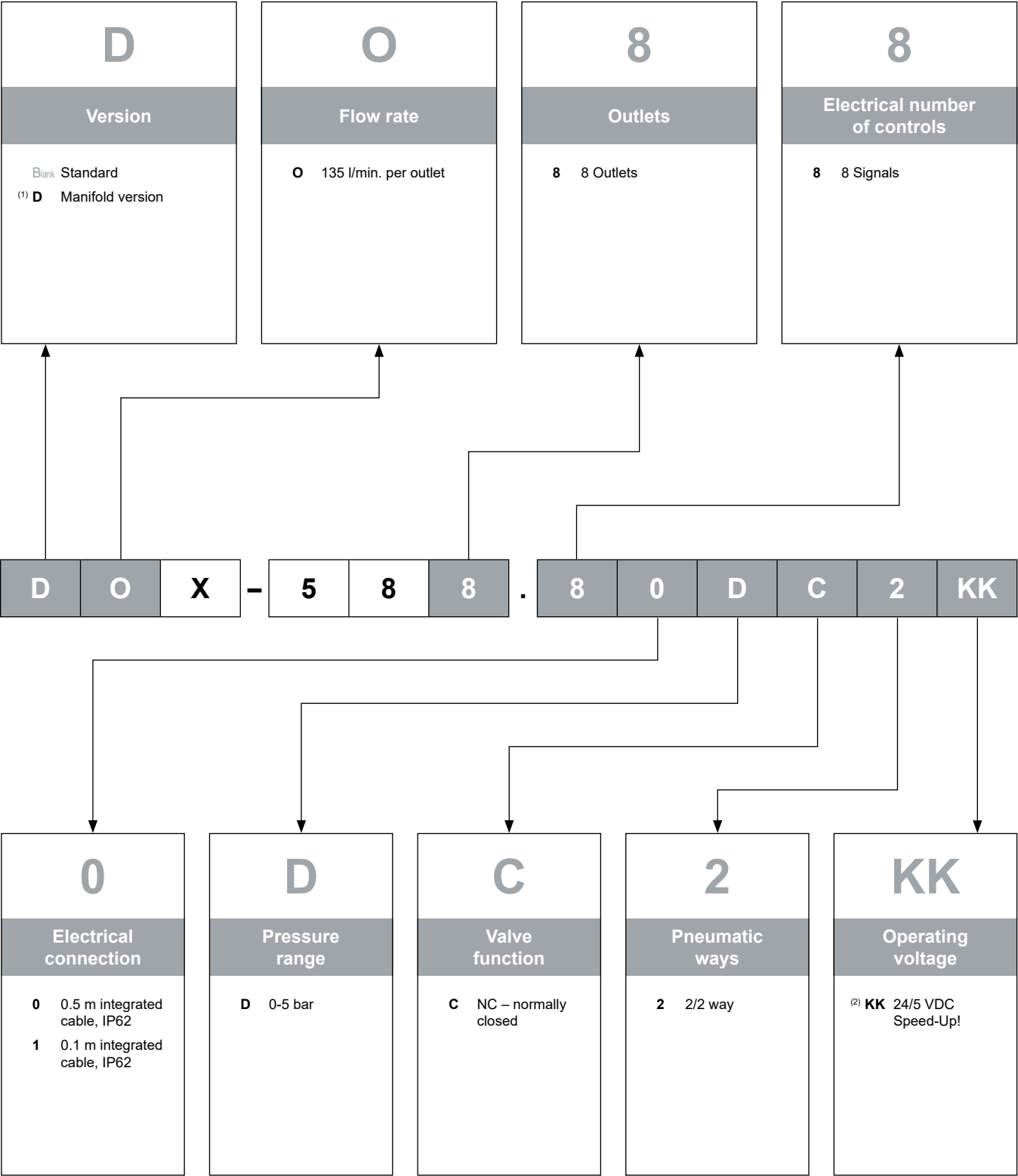

(1) without thread and plug-in connections  
 (2) Requires a Speed-Up! Control (see intro pages)

# 580 SERIES

## Drawings and connections

### Manifold mounting version

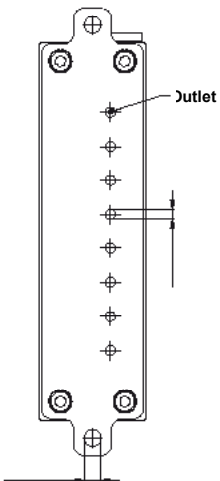
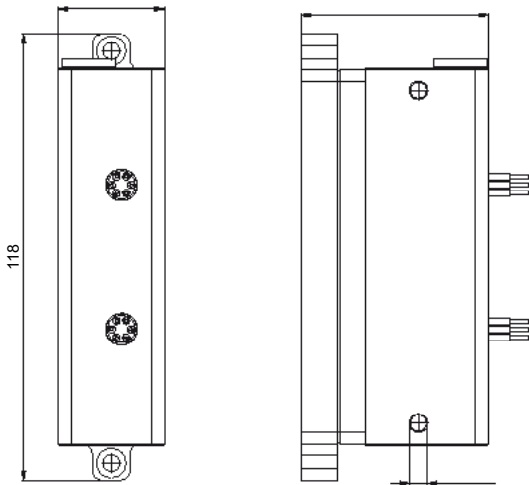
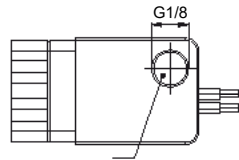
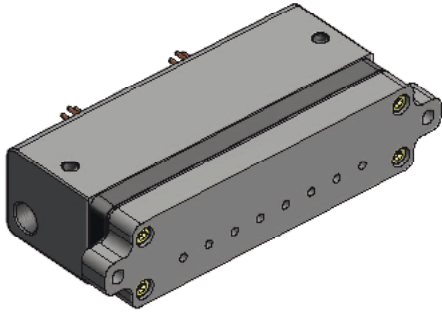

### Standard version

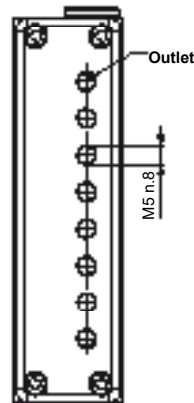
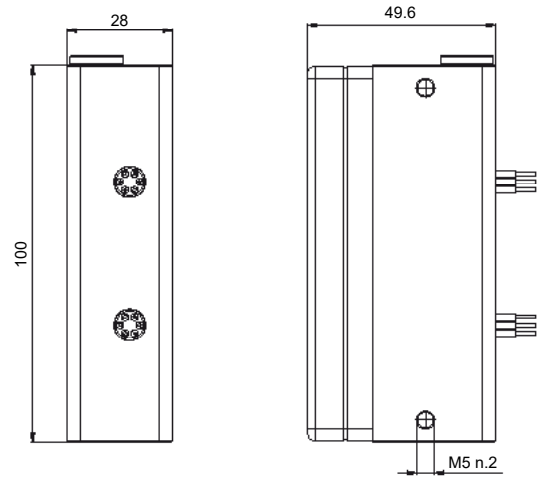
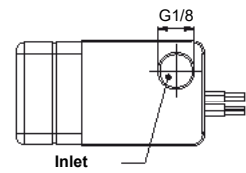
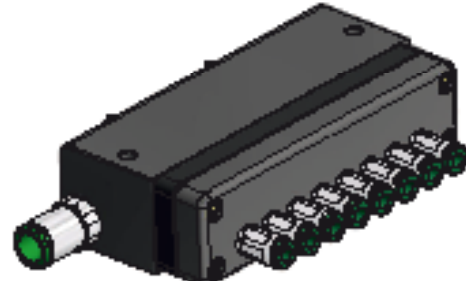



## 720 SERIES

The 720 series as individual or manifold mounting valve is available in a variety of variants. Whether for use with overpressure or vacuum, in 2/2 or 3/2 function, in NC or NO design, as individual valve or for mounting on a manifold, this valve can be configured accordingly.

Manifolds with 4 or 8 seats are available as accessories (other versions on request). A combination of NC and NO versions enables among other things a 5/2 function.

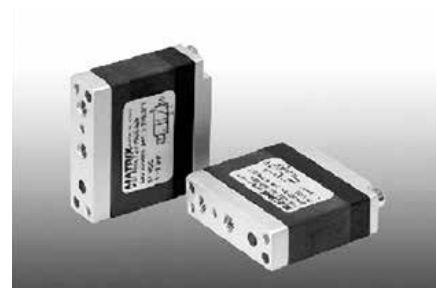

### Technical data

Switching time opening*	12/24: <7 ms	JJ: <5 ms	KK: <2 ms
Switching time closing*	12/24: <3 ms	JJ: <2 ms	KK: <2 ms
Maximum frequency	100 Hz	140 Hz	250 Hz
Weight	35 g		
Protection class	IP62		

\*Varies with the working pressure

Outlets	1
Flow rate	up to 100 l/min.
Function	2/2 or 3/2 way in NC or NO
Pressure range	between 0-8 bar or vacuum

### Possible functions

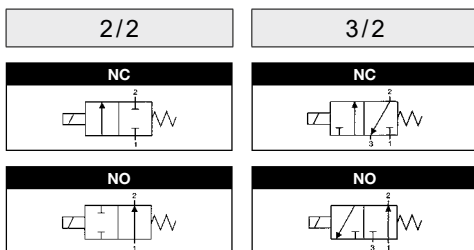

### Possible controls

**Direct / PWM / PFM**  
*Information, see Page 5*

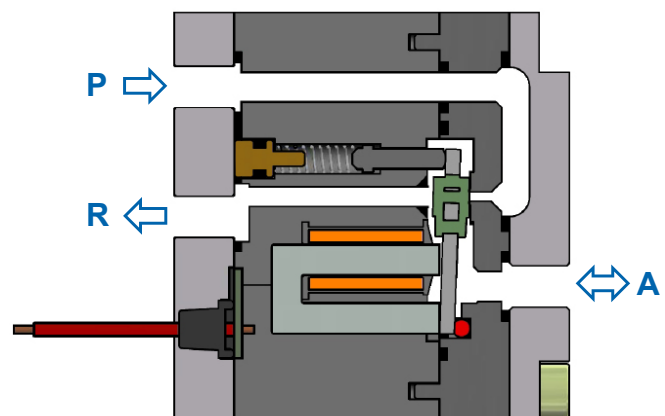

Section: Type 3/2 NC

Ordering code

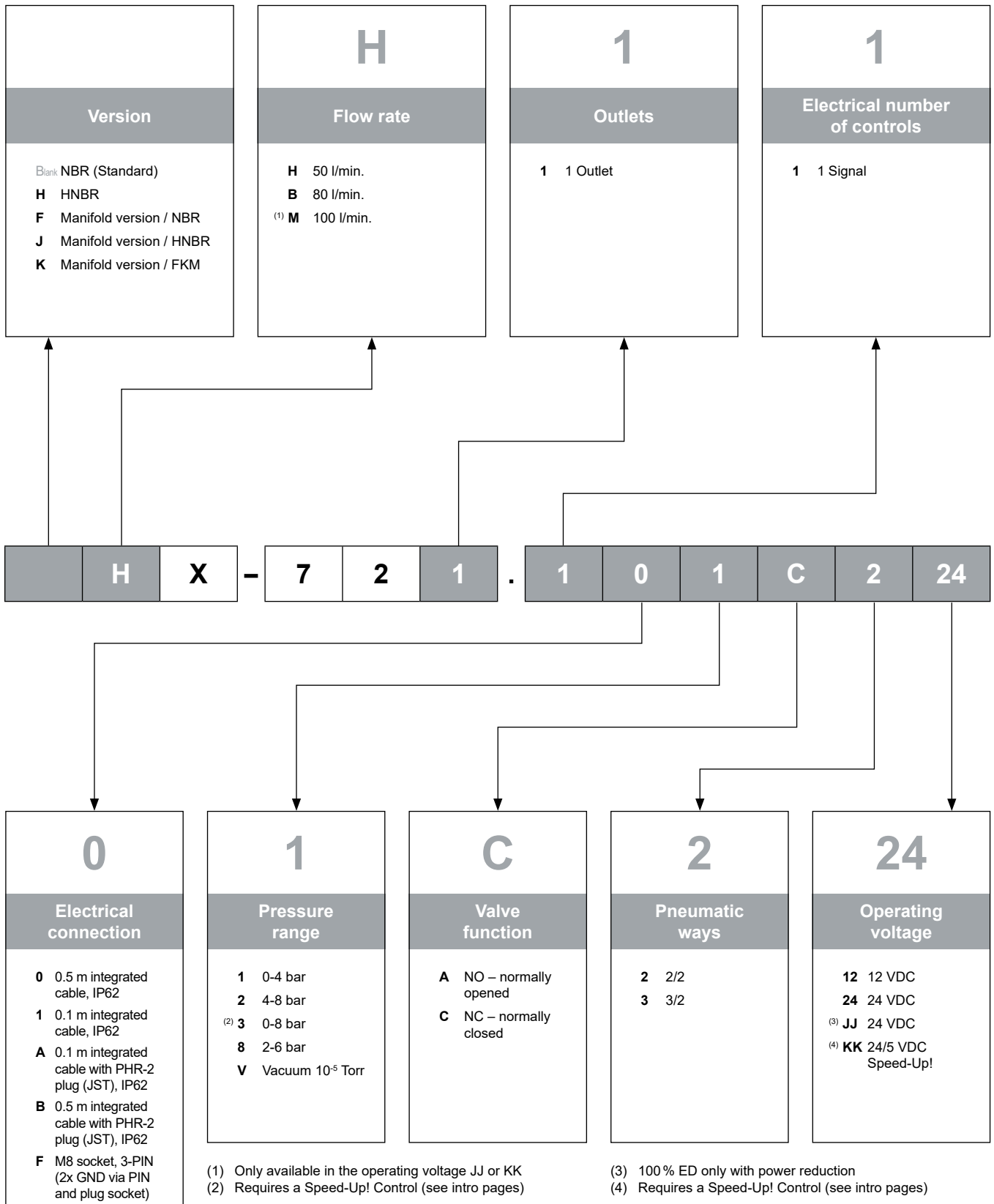



# 720 SERIES

## Drawings and connections

### Manifold mounting version

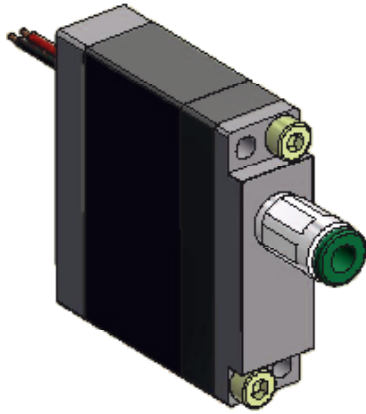

### Standard version

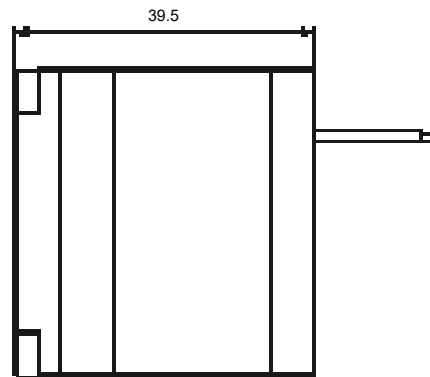
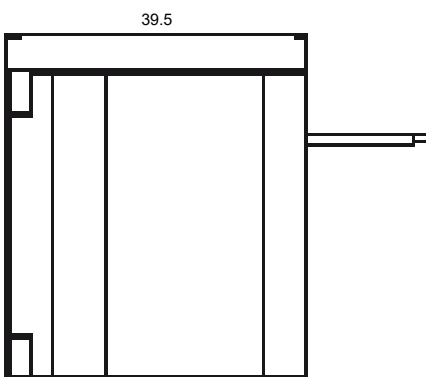
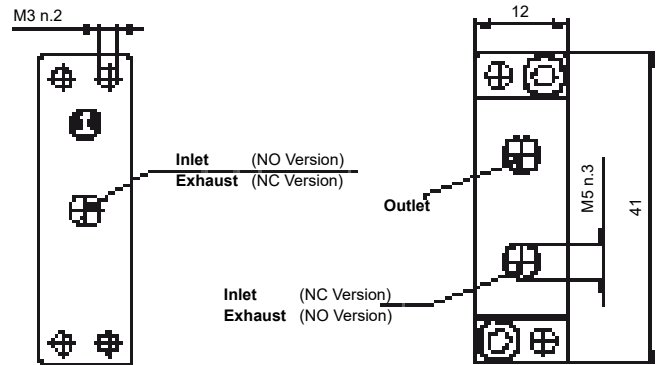
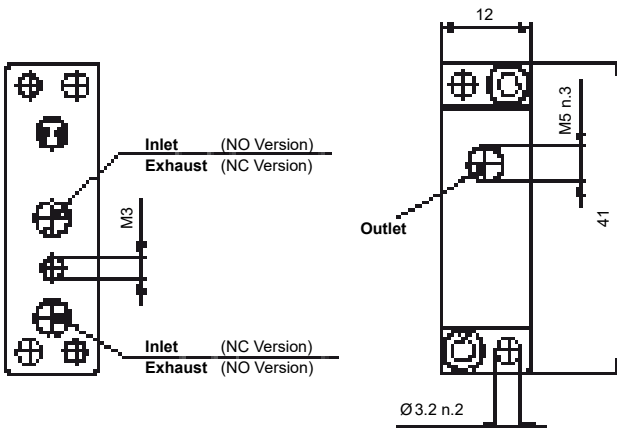
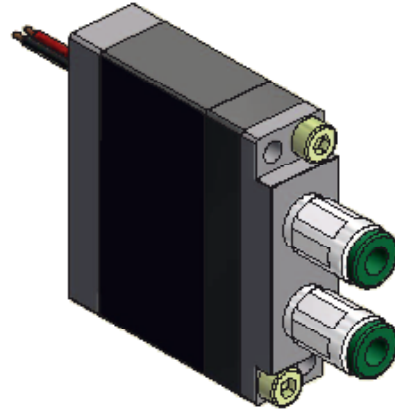

Accessories

Manifolds for 2/2 & 3/2 function

Number of seats	Article code	Dimensions	
		Y	Z
For 2 valves	<b>861.332E</b>	45 mm	35 mm
For 4 valves	<b>861.310I</b>	70 mm	60 mm
For 8 valves	<b>861.321T</b>	120 mm	110 mm

Manifold for 5/2 function

Number of seats	Article code	Dimensions	
		Y	Z
For 2 valves*	<b>861.919T</b>	27.5 mm	54 mm

\* Combination of one valve each in NC/NO for 5/2 function.

**Note:** All manifolds include mounting screws for the valves and screw connections.

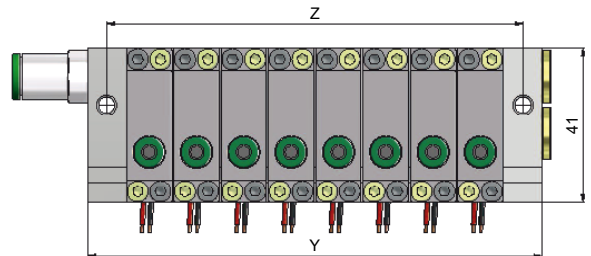
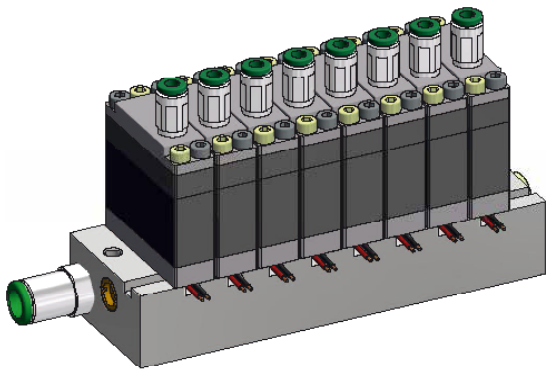

Product examples and special solutions

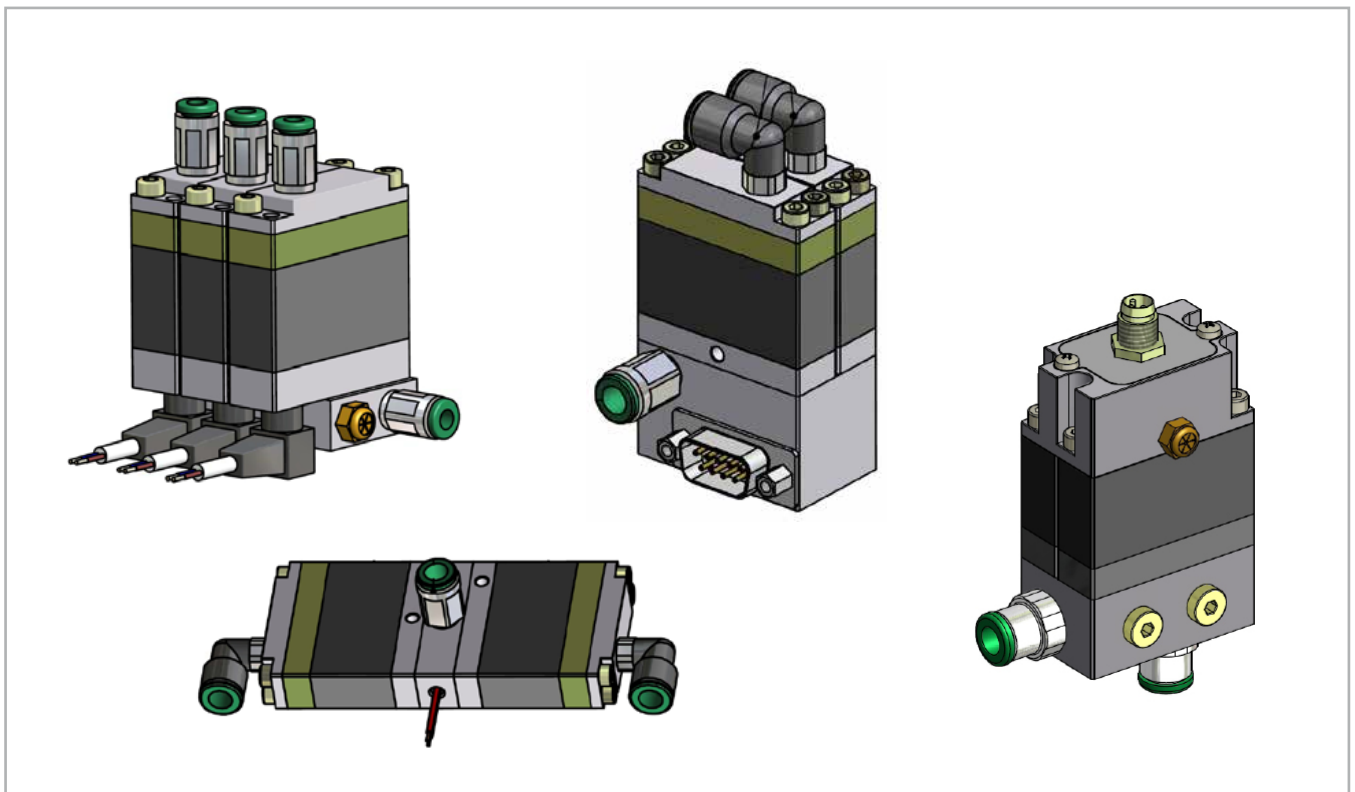

# 750 SERIES

The 750 series combines 8 valves in one basic body and can be applied as multi-valve in a wide variety of functions. Whether with overpressure or vacuum, in 2/2, 3/2, 3/3 or 5/2 function, in NC or NO version, as single module or for the multiple mounting on a manifold, this valve series can be configured accordingly.

A further feature is the possibility to supply the valve with two different pressures or to combine pressure and vacuum. Among other things this enables Pick-and-Place applications with only one multi-valve.

Manifolds with 2 to 8 seats are available as accessories. The combination of different way functions in NC or NO, pressure and vacuum as well as different flow capacity is possible.

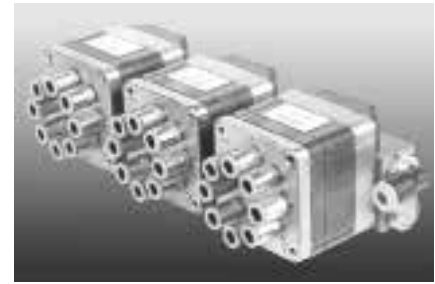

## Technical data

Switching time opening*	12/24: <7 ms	JJ: <5 ms	KK: <2 ms
Switching time closing*	12/24: <3 ms	JJ: <2 ms	KK: <2 ms
Maximum frequency	100 Hz	140 Hz	250 Hz
Weight	<b>751:</b> 380 g / <b>752:</b> 330 g / <b>754:</b> 340 g / <b>758:</b> 350 g		
Protection class	IP52 – IP62 – IP65		

\*Varies with the working pressure

Outlets	1, 2, 4 or 8
Flow rate	up to 700 l/min.
Function	2/2 or 3/2 way in NC or NO
Pressure range	between 0-8 bar or vacuum

## Possible functions

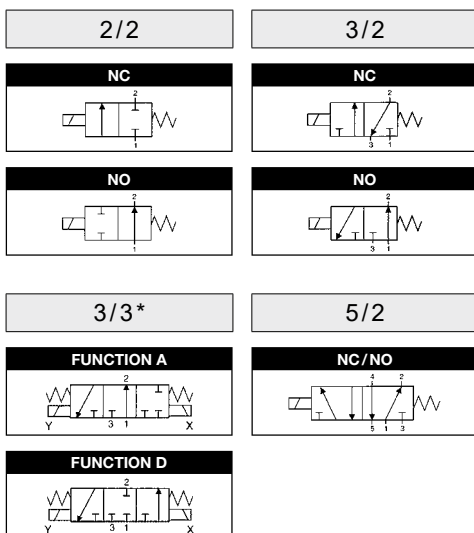

\*Technical data on request.

## Possible controls

Direct / PWM / PFM / PNM / Combination  
Information, see Page 5

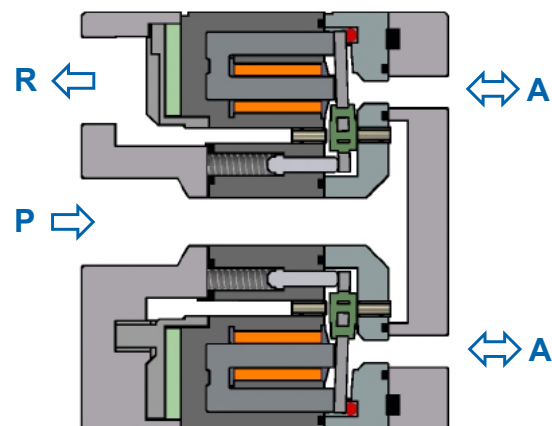

Section: Type 3/2 NC

Ordering code

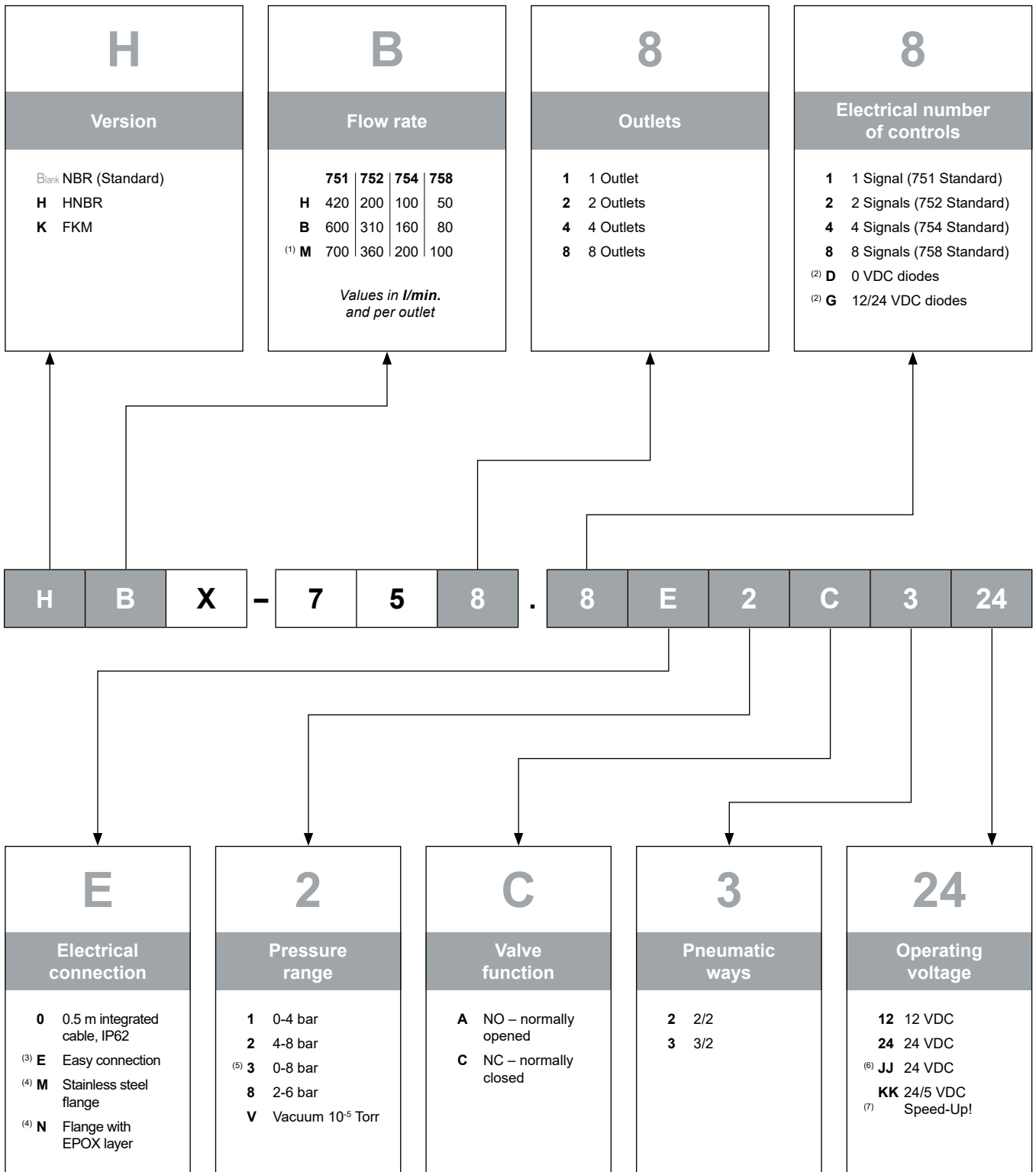

(1) Only available in the operating voltage JJ or KK  
 (2) Integrated diodes only for version 754/758 with 4/8 signals  
 (3) Easy Plug System – see accessories.  
 Not available for valves with 1 or 2 signal cables.

(4) Including Easy Connection  
 (5) Only available in the operating voltage KK  
 (6) 100% ED only with power reduction

(7) Requires a Speed-Up! Control (see intro pages)

# 750 SERIES

## Drawings and connections

### Type 751

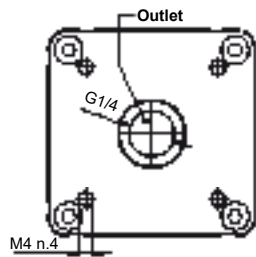
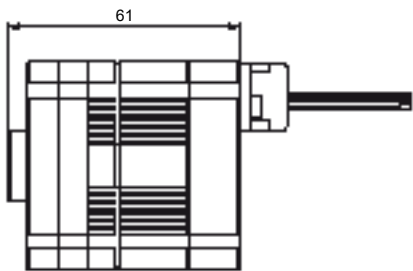
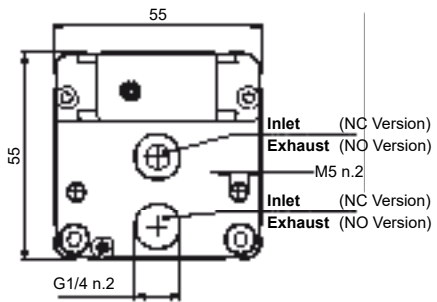
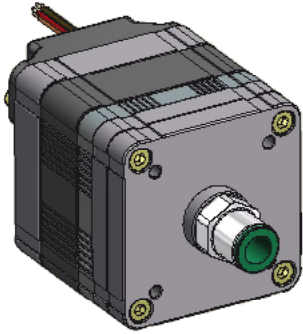

### Type 752

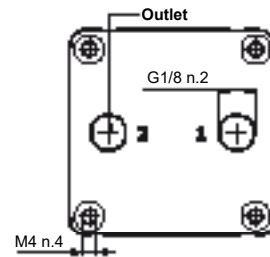
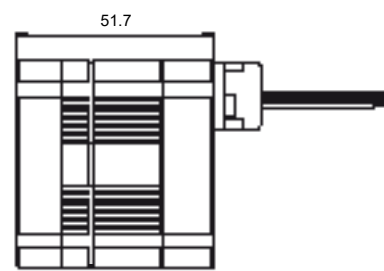
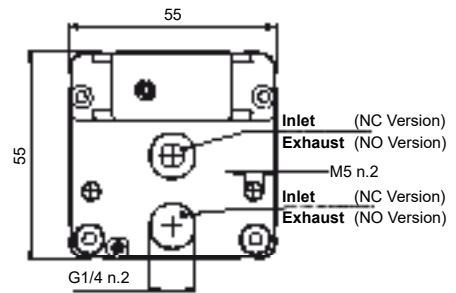
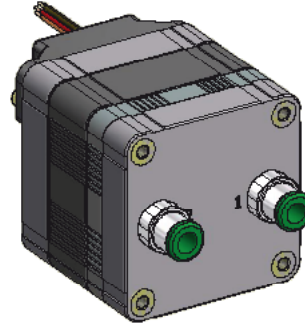

Drawings and connections

Type 754

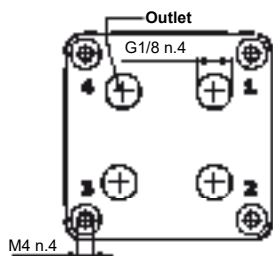
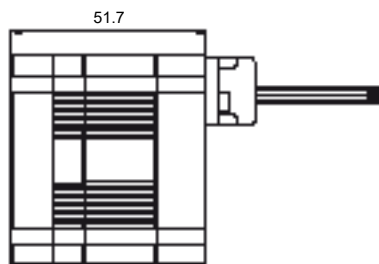
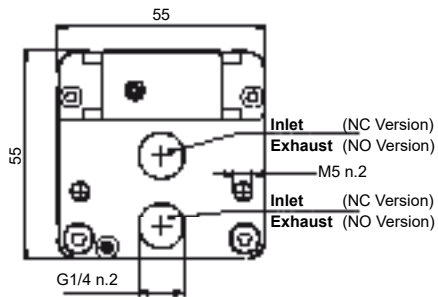
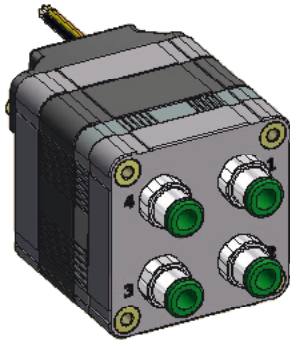

Type 758

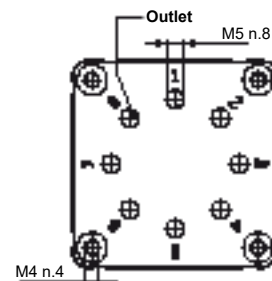
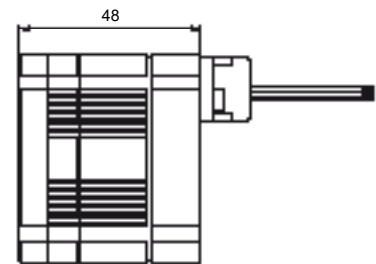
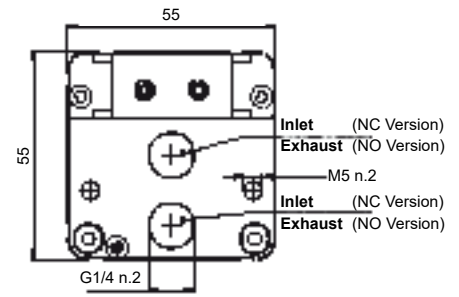
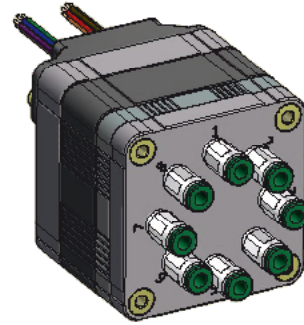

# 750 SERIES

## Ordering code

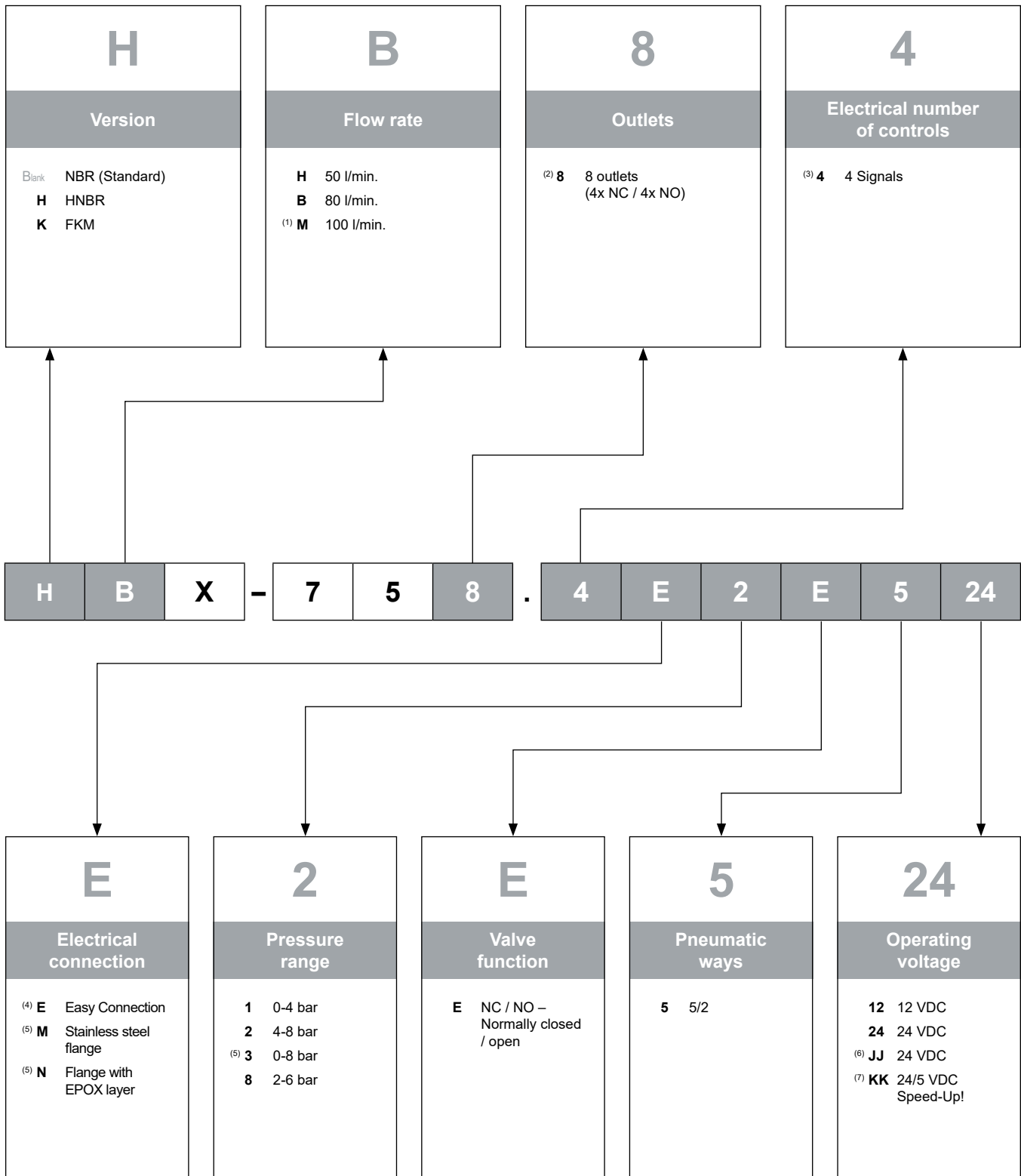

(1) Only available in the operating voltage JJ or KK  
 (2) 4x NC and 4x NO in combination (= 4x 5/2 way, monostable)  
 (3) 4 signals, of which 1 signal each for 2 outlets

(4) Easy Connector System – see accessories  
 (5) Including Easy Connection  
 (6) Only available in the operating voltage KK

(7) 100% ED only with power reduction  
 (8) Requires a Speed-Up! Control (see intro pages)



## Technical data

Switching time opening*	12/24: <5 ms	JJ: <5 ms	KK: <2 ms
Switching time closing*	12/24: <3 ms	JJ: <3 ms	KK: <2 ms
Maximum frequency	100 Hz	100 Hz	150 Hz
Weight	380 g		
Protection class	IP52 – IP65		

\*Varies with the working pressure

Outlets	8
Flow rate	up to 100 l/min.
Function	5/2 way, monostable
Pressure range	between 0-8 bar

## Drawings and connections

### Type 758 5/2

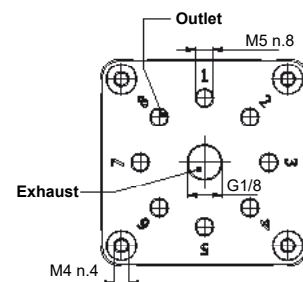
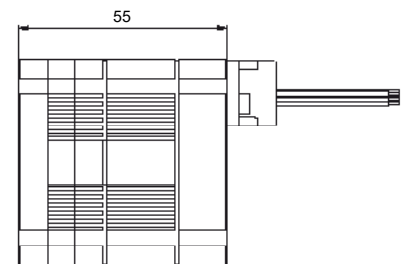
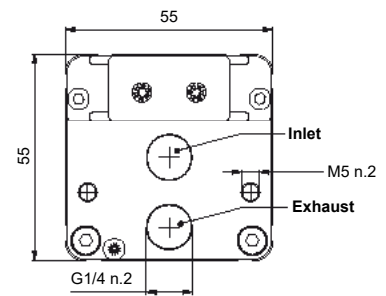
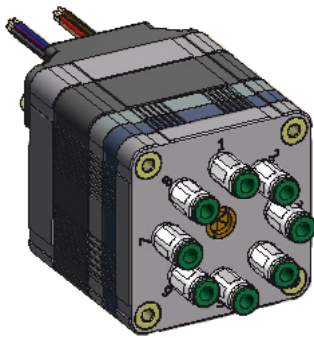

# 750 SERIES

## Ordering code

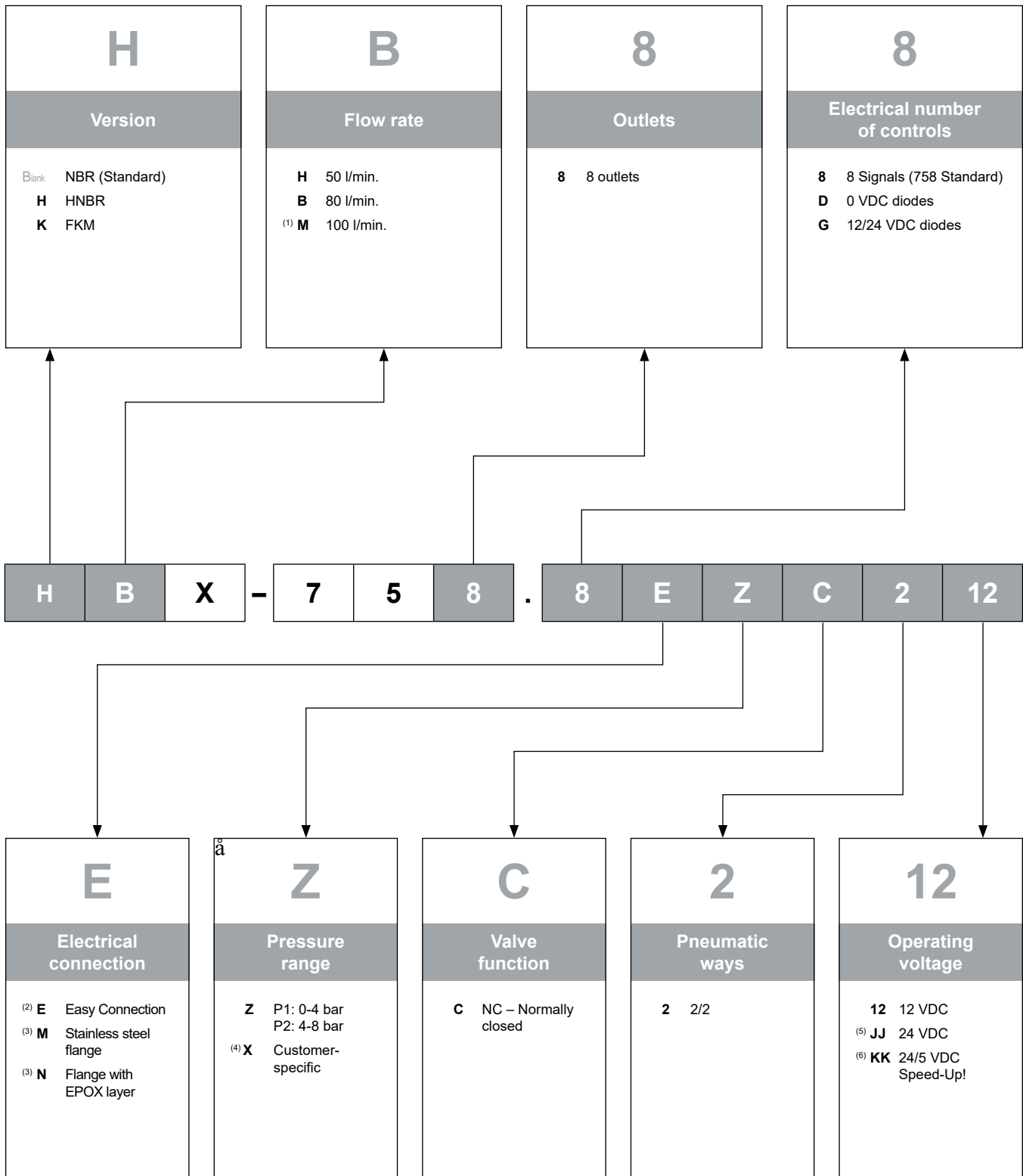

(1) Only available in the operating voltage JJ or KK  
 (2) Easy Connector System – see accessories  
 (3) Including Easy Connection

(4) Combination of pressure/vacuum possible (e.g. for Pick-and-Place)  
 (5) 100% ED only with power reduction  
 (6) Requires a Speed-Up! Control (see intro pages)

Technical data

Switching time opening*	12/24: <7 ms	JJ: <5 ms	KK: <2 ms
Switching time closing*	12/24: <3 ms	JJ: <2 ms	KK: <2 ms
Maximum frequency	100 Hz	140 Hz	250 Hz
Weight	350 g		
Protection class	IP52 – IP65		

\*Varies with the working pressure

Outlets	8
Flow rate	up to 100 l/min.
Function	2/2 way
Pressure range	between 0-8 bar

Drawings and connections

Type 758 DS 2/2

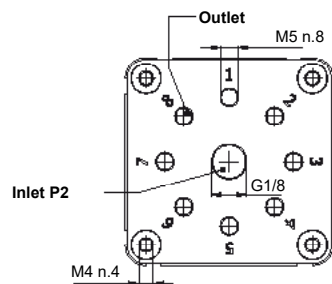
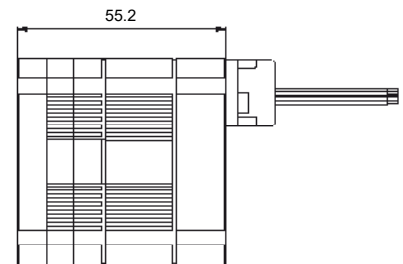
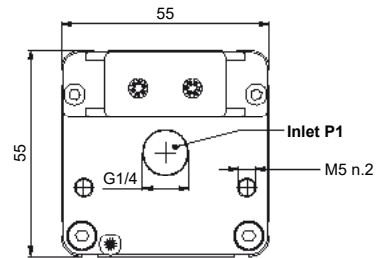
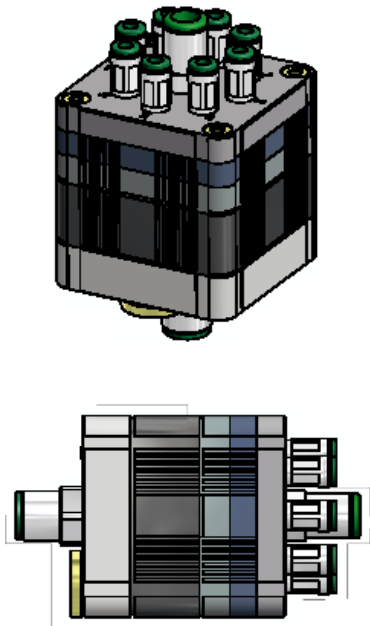

# 750 SERIES

## Accessories

### Manifolds for 2/2 & 3/2 function

Number of seats	Article code	Dimensions	
		Y	Z
For 2 multi-valves	<b>868.950E</b>	140 mm	130 mm
For 3 multi-valves	<b>868.951F</b>	195 mm	65 mm
For 4 multi-valves	<b>868.952G</b>	260 mm	130 mm
For 5 multi-valves	<b>868.953H</b>	325 mm	195 mm
For 6 multi-valves	<b>868.954I</b>	390 mm	260 mm
For 7 multi-valves	<b>868.955J</b>	455 mm	325 mm
For 8 multi-valves	<b>868.956K</b>	520 mm	390 mm

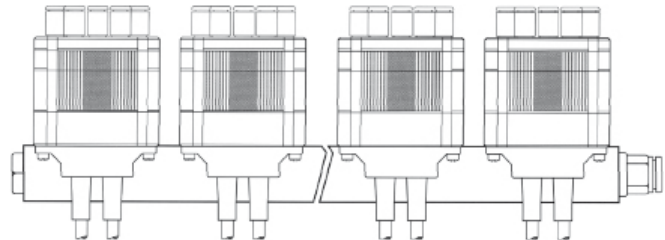
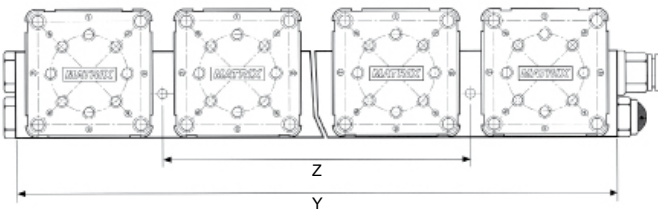
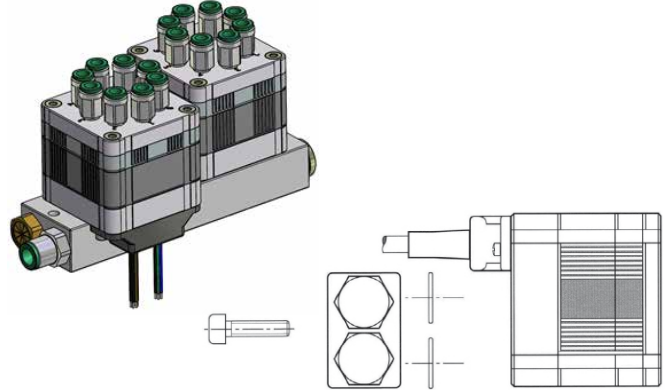

**Note:** All manifolds include mounting screws for the valves and screw connections.

### Mounting bracket 90°

For valve version	Article code
With integrated cable	<b>868.466O</b>
With Easy Connection	<b>869.314E</b>

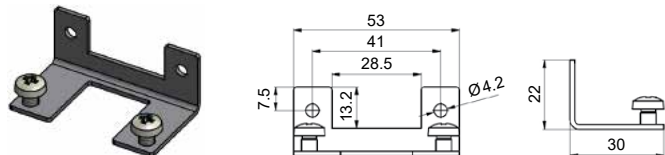

**Note:** Mounting bracket includes mounting screws for the valve.

### IP52 Valve cable AWG 24

Length	Article code		
	2	4	8
500 mm	<b>868.870C</b>	<b>868.871D</b>	<b>868.872E</b>
1,000 mm	<b>868.873F</b>	<b>868.875H</b>	<b>868.877J</b>
2,000 mm	<b>868.874G</b>	<b>868.876I</b>	<b>868.878K</b>
3,000 mm	<b>868.845D</b>	<b>868.880M</b>	<b>868.881N</b>

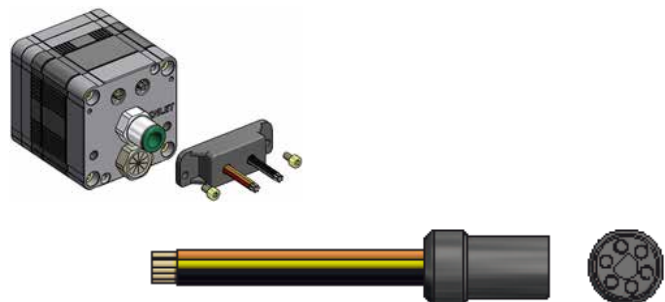

### IP65 PVC valve cable AWG 24

Length	Article code	
	Controls	
	4	8
1,000 mm	<b>868.851J</b>	<b>868.850I</b>
2,000 mm	<b>868.854M</b>	<b>868.852K</b>
3,000 mm	<b>868.855N</b>	<b>868.853L</b>

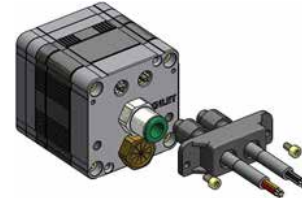

### IP65 PUR valve cable AWG 24

Length	Article code	
	Controls	
	4	8
2,000 mm	<b>868.883P</b>	<b>868.885R</b>
4,000 mm	<b>868.884Q</b>	<b>868.886S</b>
5,000 mm	<b>869.892K</b>	<b>869.865J</b>



### Valve cable with optional D-Sub 15 PIN connector

#### IP52 valve cable plus D-Sub 15 PIN connector

Length	Article code	
	Controls	
	4	8
500 mm	<b>868.871D.15</b>	<b>868.872E.15</b>
1,000 mm	<b>868.875H.15</b>	<b>868.877J.15</b>
2,000 mm	<b>868.876I.15</b>	<b>868.878K.15</b>
3,000 mm	<b>868.880M.15</b>	<b>868.881N.15</b>

#### IP65 PVC valve cable plus D-Sub 15 PIN connector

Length	Article code	
	Controls	
	4	8
1,000 mm	<b>868.851J.15</b>	<b>868.850I.15</b>
2,000 mm	<b>868.854M.15</b>	<b>868.852K.15</b>
3,000 mm	<b>868.855N.15</b>	<b>868.853L.15</b>

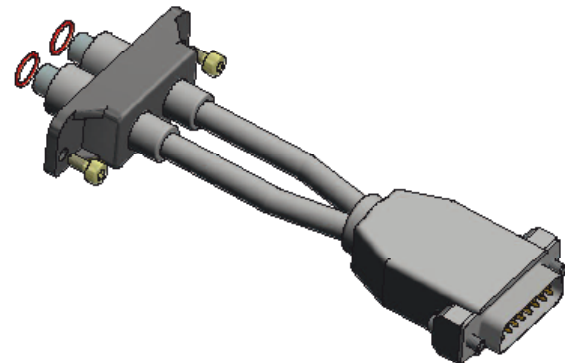

#### IP65 PUR valve cable plus D-Sub 15 PIN connector

Length	Article code	
	Controls	
	4	8
2,000 mm	<b>868.883P.15</b>	<b>868.885R.15</b>
4,000 mm	<b>868.884Q.15</b>	<b>868.886S.15</b>
5,000 mm	<b>869.892K.15</b>	<b>869.865J.15</b>

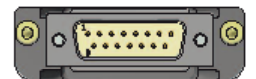

Illustration shows IP65 cable

## 750 SERIES

The class of protection specifies the suitability of electrical equipment for various ambient conditions. With regard to their suitability, the protected systems are classified in corresponding protection classes, so-called IP-Codes. The letters IP in the protection class designation are appended with two indicators. These indicate what scope of protection a housing provides against foreign matter and moisture.

### IP52

- 5: Protected against dust in harmful quantity, complete protection against contact.
- 2: Protection against falling drops of water, when the housing is inclined up to 15°.

### IP65

- 6: Dust-tight, complete protection against contact.
- 5: Protection against water jet (nozzle) from any angle.

More precise explanations can be found in the respective standards.

## Easy Connector System for 750 series MATRIX valves

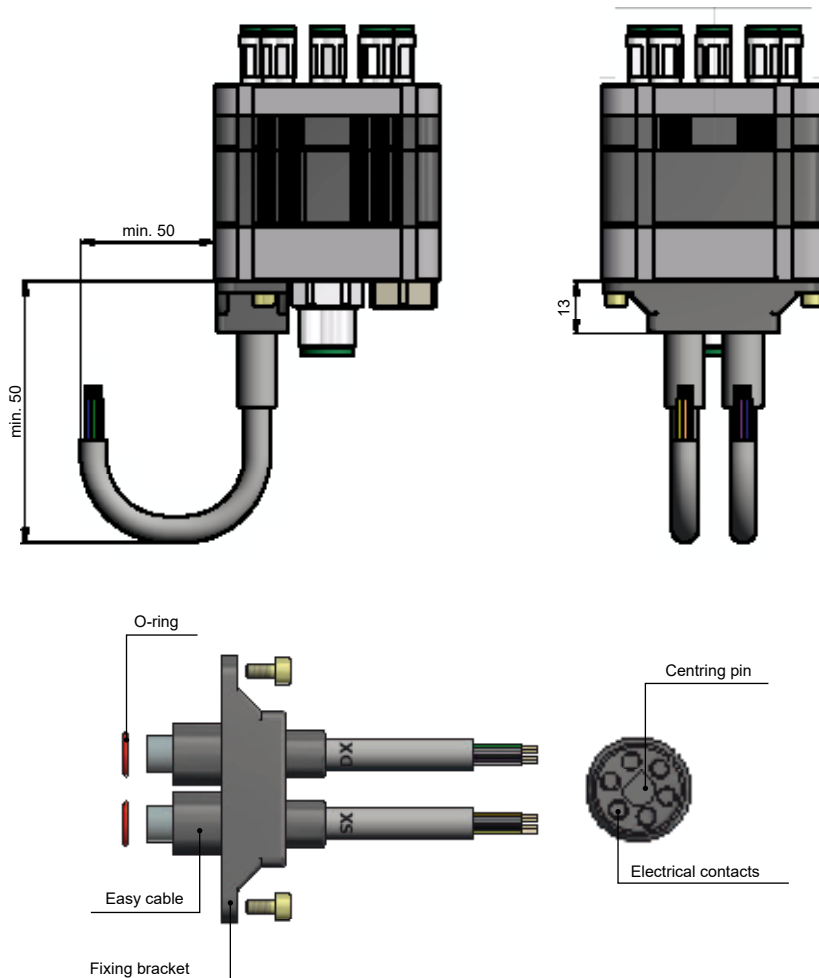

Product examples and special solutions

“One of our *strengths* is  
the offer for *customer-specific solutions*  
in order to *perfectly* fulfil your requirements  
and achieve the best possible *results.*”

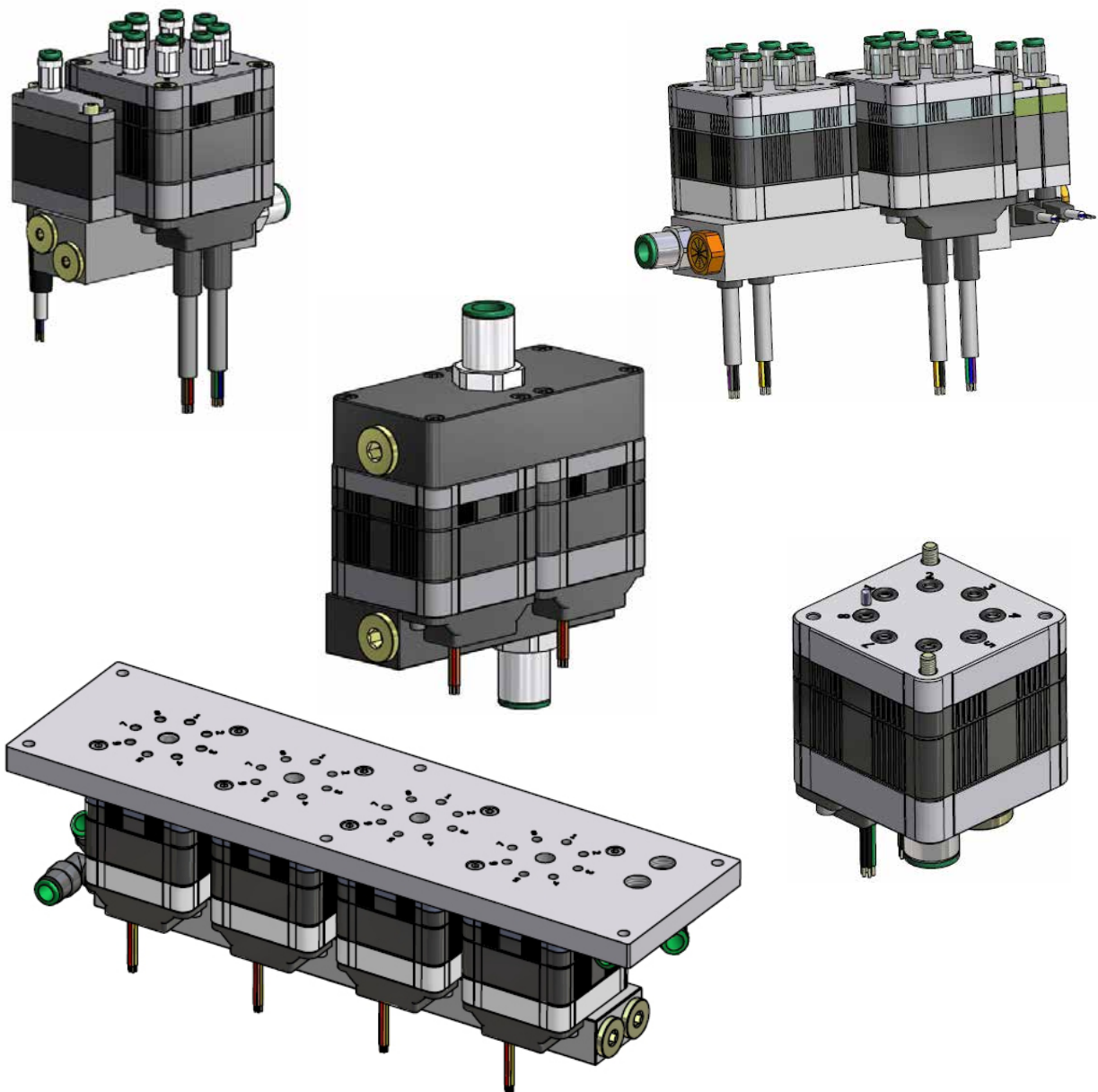



## 820 SERIES

The 820 series is a valve with 2/2 function in NC (normally closed). A combination of two of these valves produces a 3/3 function in NC/NC. The 820 series was designed especially to create a compact 2/2 valve with high performance. Switching times of < 1 ms for the complete opening or closing phase, a flow capacity of up to 220 l/min. and a frequency of max. 500 Hz are configurable depending on the version. This high performance and dynamic is achieved through the unique and patented MATRIX technology and enables an outstanding repeat accuracy.

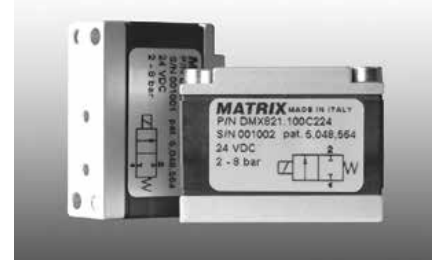

The features of this valve series are particularly suitable in applications which demand a high standard of reliability, constant process quality or also if no readjustment is desired in plants. The 820 series is available as individual valve as well as manifold mounting valve. Manifolds with 4 or 8 seats are available as accessories (other versions on request).

### Technical data

Switching time opening*	24: < 5 ms	KK: < 1 ms	XX...KK: < 2 ms
Switching time closing*	24: < 2 ms	KK: < 1 ms	XX...KK: < 2 ms
Maximum frequency	140 Hz	500 Hz	50 Hz
Weight	25 g		
Protection class	IP62		

\*Varies with the working pressure

Outlets	1
Flow rate	up to 220 l/min.
Function	2/2 way in NC
Pressure range	between 0-8 bar

### Possible functions



\* Technical data on request.

### Possible controls

Direct / PWM / PFM  
Information, see Page 5

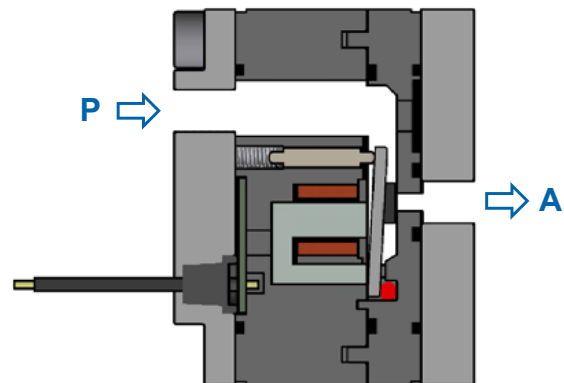

Section: Type 2/2 NC

Ordering code

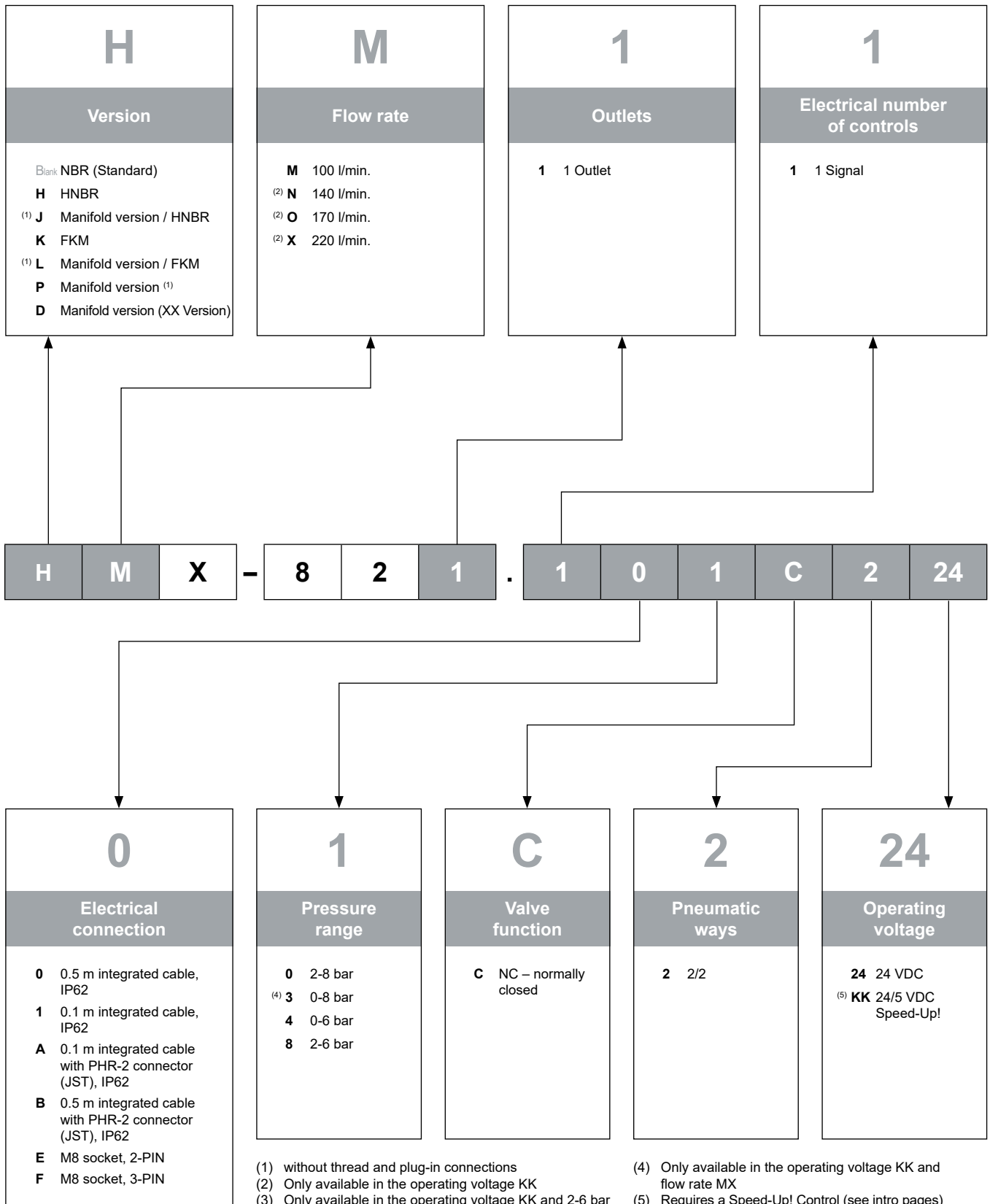

# 820 SERIES

## Drawings and connections

### Manifold mounting version

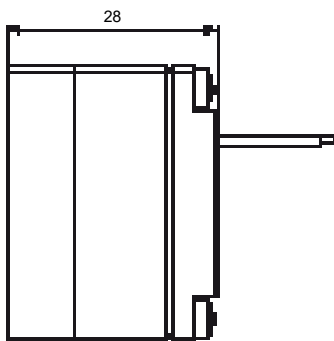
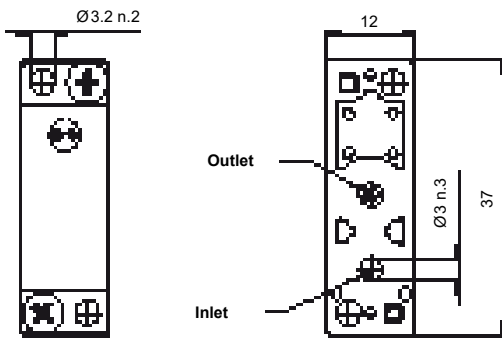
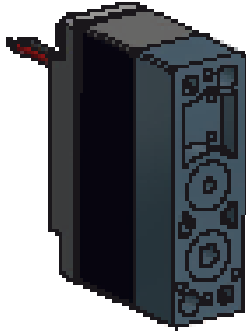

### Standard version

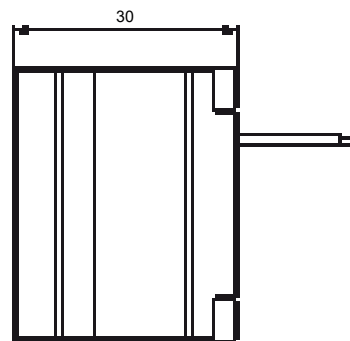
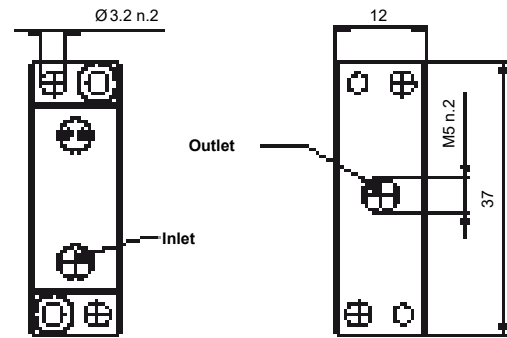
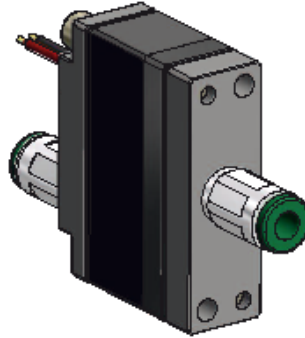

Product examples and special solutions

*“We create your **interfaces** on our products so that you can implement our products with the least **amount of engineering.**”*

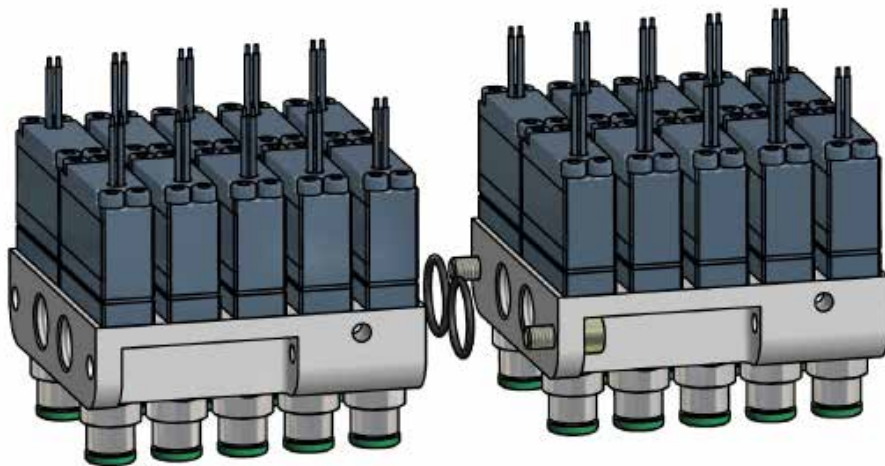
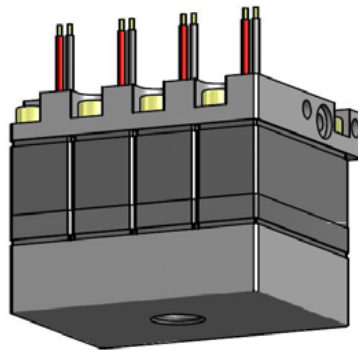
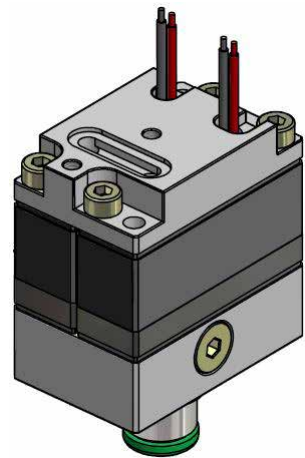
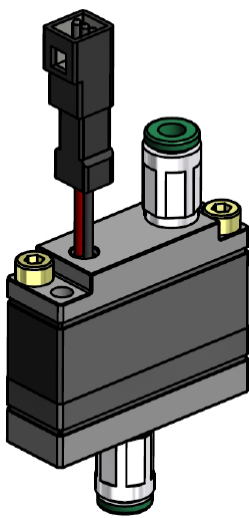

## 820 ISD SERIES

The 820 ISD series (ISD = Integrated Speed-Up Driver) is an addition to the 820 series. In addition this series has a miniature controller, which is integrated directly on the valve. In this version the Speed-Up technology is the standard for high performance. For this the integrated miniature controller takes over the control of the Speed-Up switching.

As a result the valve can be operated with a standard 24 V signal without separate requirements or adaptations to existing controllers. With a switching time of < 2 ms for the complete opening or closing phase, a frequency of max. 300 Hz can be achieved with a max. flow capacity of 180 l/min.



The 820 ISD series can be used for the direct mounting on a manifold or in combination with a mounting flange also equipped with push-in fittings.

### Technical data

Switching time opening*	YY: <2 ms	WW: <2 ms
Switching time closing*	YY: <2 ms	WW: <2 ms
Maximum frequency	300 Hz	250 Hz
Weight	25 g	
Protection class	IP67	IP62

\*Varies with the working pressure

Outlets	1
Flow rate	up to 170 l/min.
Function	2/2 way in NC
Pressure range	between 0-8 bar

### Possible function

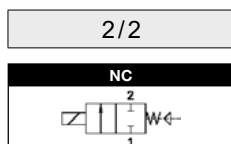

### Possible control

**Direct / PWM / PFM**  
Information, see Page 5

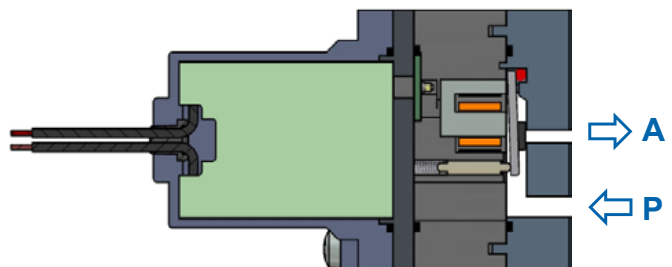

Section: Type 2/2 NC

Ordering code

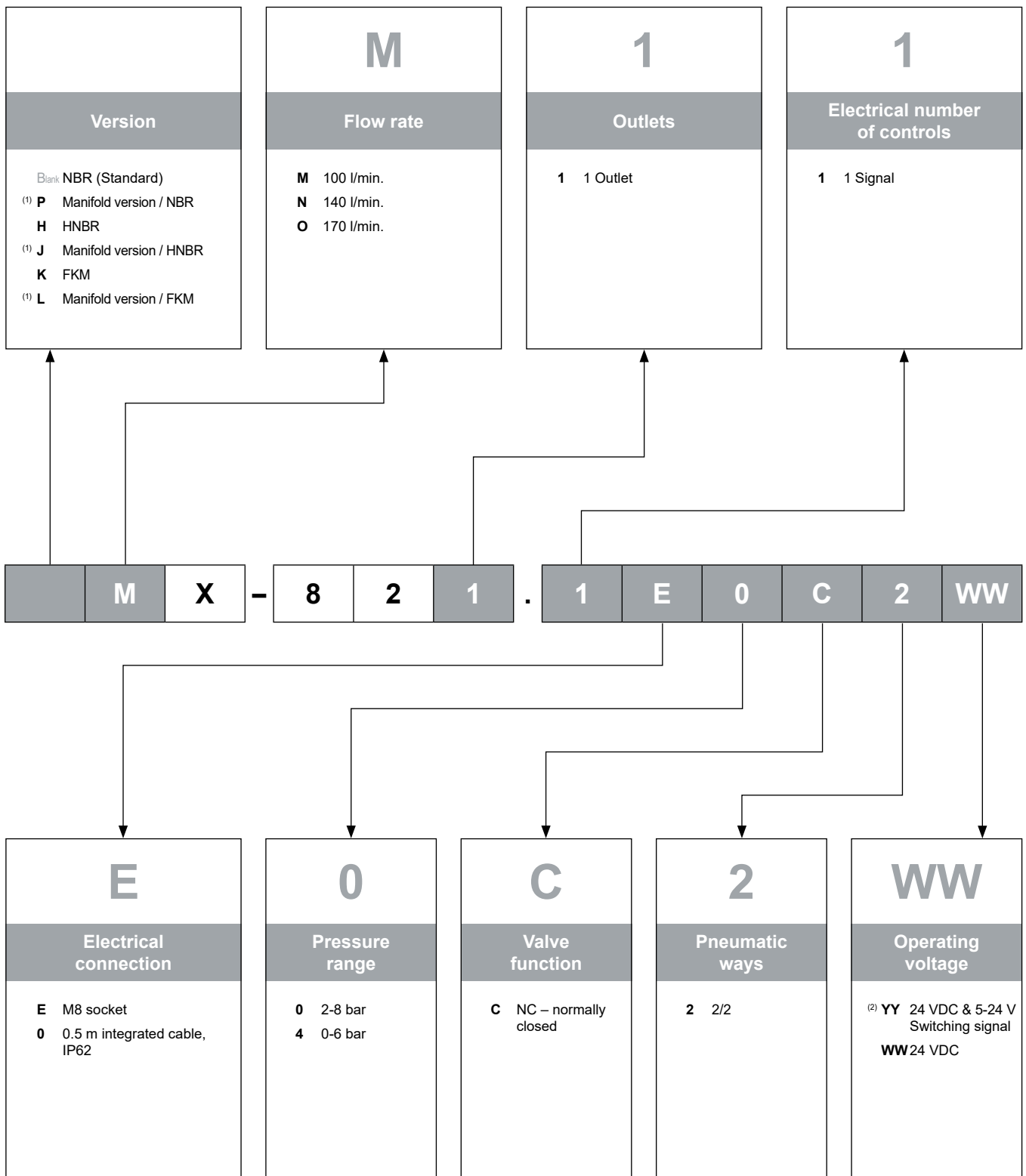

(1) without thread and plug-in connections  
 (2) 1x 24 VDC supply voltage & 1x 5-24 V switching signal (e.g. PLC)

# 820 ISD SERIES

## Drawings and connections

### Manifold mounting version

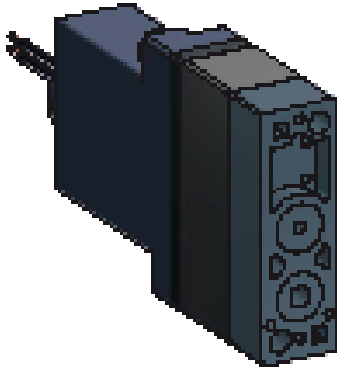

### Standard version

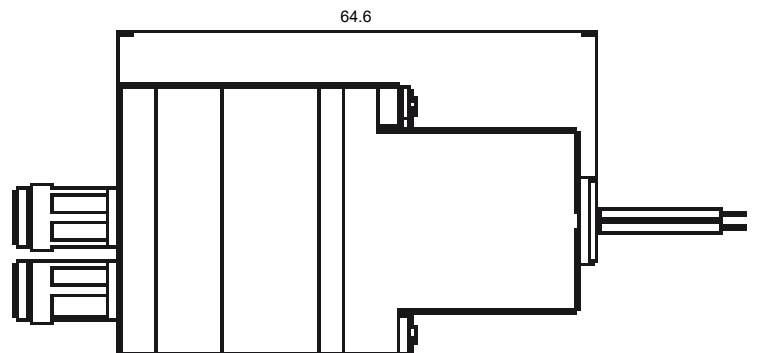
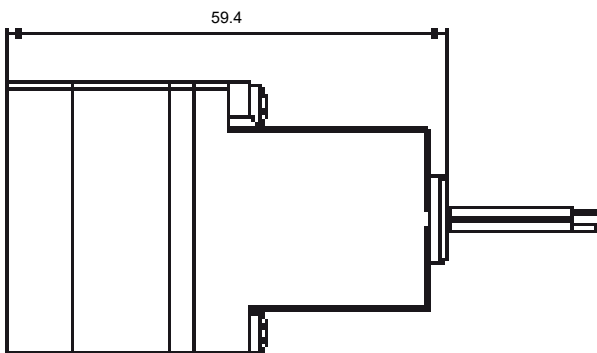
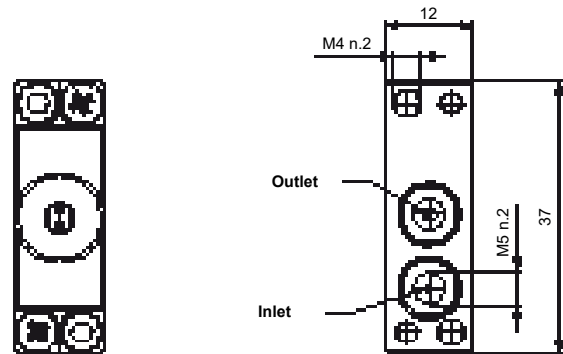
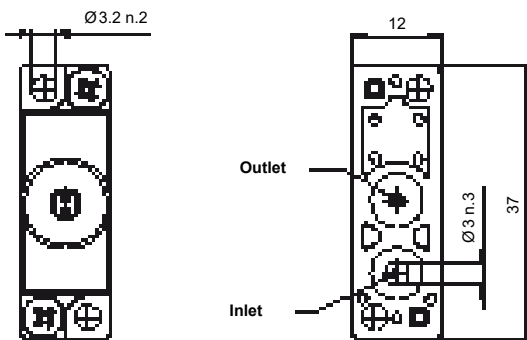
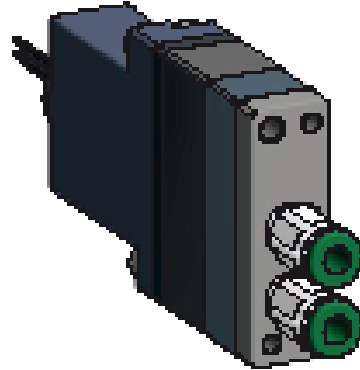



Accessories

Manifolds for 2/2

Number of seats	Article code	Dimensions	
		Y	Z
For 4 valves	<b>820.041B</b>	70 mm	60 mm
For 8 valves	<b>820.042C</b>	120 mm	110 mm

**Note:** All manifolds include mounting screws for the valves and screw connections.

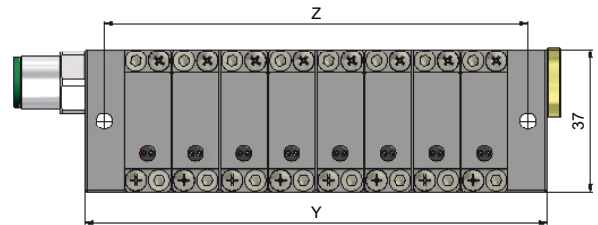
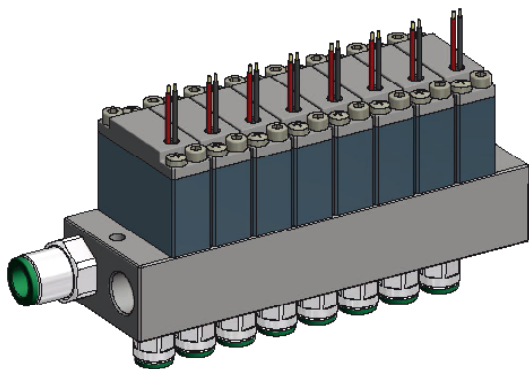

Product examples and special solutions

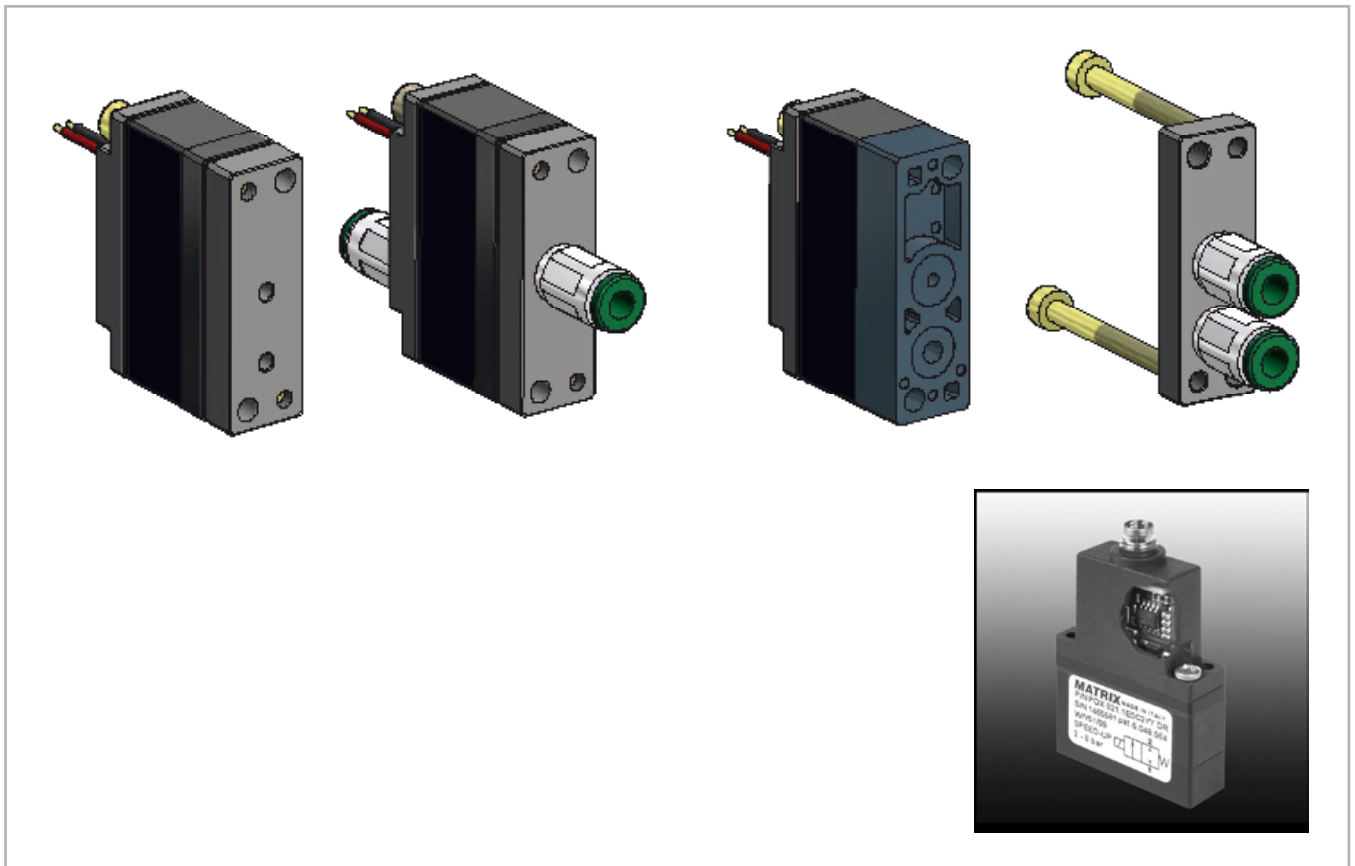

## 860 SERIES

With the 860 valve series MATRIX offers an unprecedented simple, compact and precise Digital Flow Control valve.

In a compact valve body of just 55 x 55 x 52 mm, 9 valves with 2/2 function in NC (normally closed) are combined on one pneumatic inlet/outlet. Each valve has a different nominal diameter and can be switched independently. This enables a proportional and/or linear flow rate.

Two configurations are available for a 6-Bit (64 levels) or 8-Bit (256 levels) control. Consequently, with the PCM technology up to 256 different, unambiguously defined as well as reproducible flow rate values can be set. The switchover between the respective levels takes place within a millisecond. This extraordinary performance is achieved through the unique and patented valve technique of MATRIX. With the MATRIX PCM control card the valve can be controlled by means of an input signal of 0-10 V, which is subsequently converted to binary codes.



### Technical data

Switching time opening*	< 1 ms
Switching time closing*	< 1 ms
Maximum frequency	500 Hz
Weight	450 g
Protection class	IP52

\*Varies with the working pressure

Outlets	1
Flow rate	up to 750 l/min.
Function	2/2 way in NC
Pressure range	between 0-6 bar

### Possible function

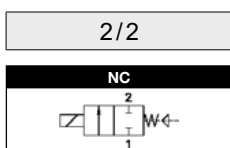

### Possible controls

**Direct / PWM / PFM / PNM / PCM / Combination**  
*Information, see Page 5*

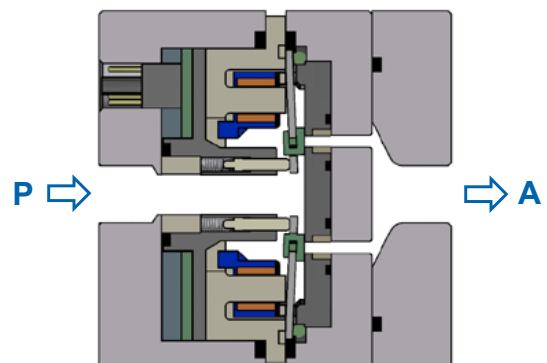

*Section: Type 2/2 NC*

Variable flow rate with 6-Bit (64 levels) or 8-Bit (256 levels) resolution.

Type PX with 6-Bit resolution

Flow rate: min. 1.7 l/min. @ 1 bar  
max. 750 l/min. @ 6 bar

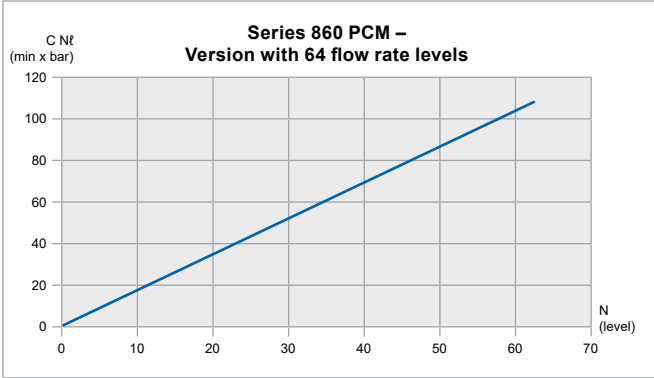

Characteristic of the flow rate when varying N (64 levels)

Type QX with 8-Bit resolution

Flow rate: min. 0.3 l/min. @ 1 bar  
max. 500 l/min. @ 6 bar

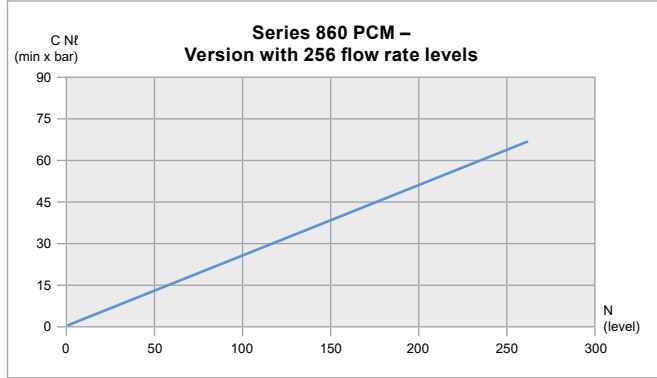

Characteristic of the flow rate when varying N (256 levels)

Extremely fast change of the flow rate level with very precise reproducibility

The performance of the MATRIX valves enables each of the 64 or 256 flow rate levels to be set within 2 milliseconds. Among other things, in process applications that enables a variety of individual process settings/changes during or in between the processes and consequently higher productivity as well as constant quality due to the reproducibility.

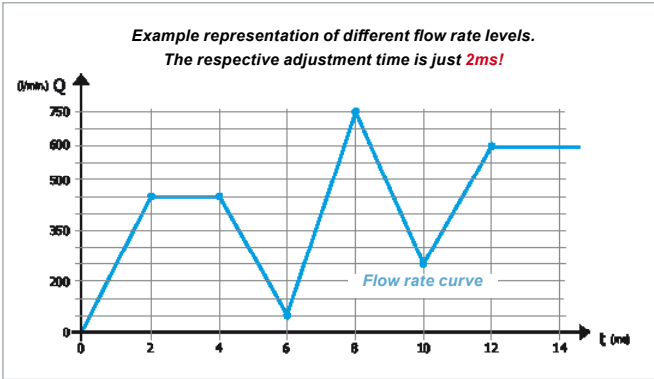

Example of the adjustment time between the flow rate levels (Fig. The 6-Bit Version)

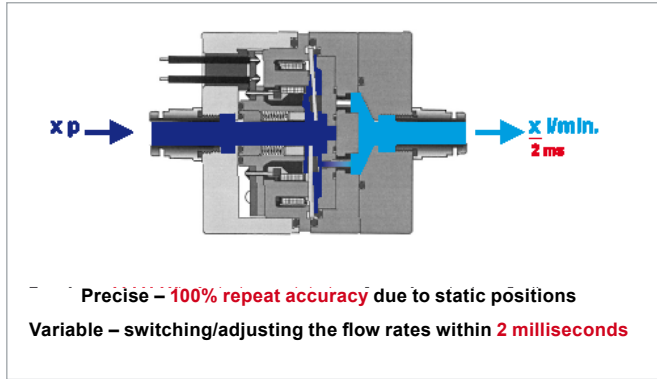

Series 861 PCM with variable flow rate • 2/2

# 860 SERIES

## Ordering code

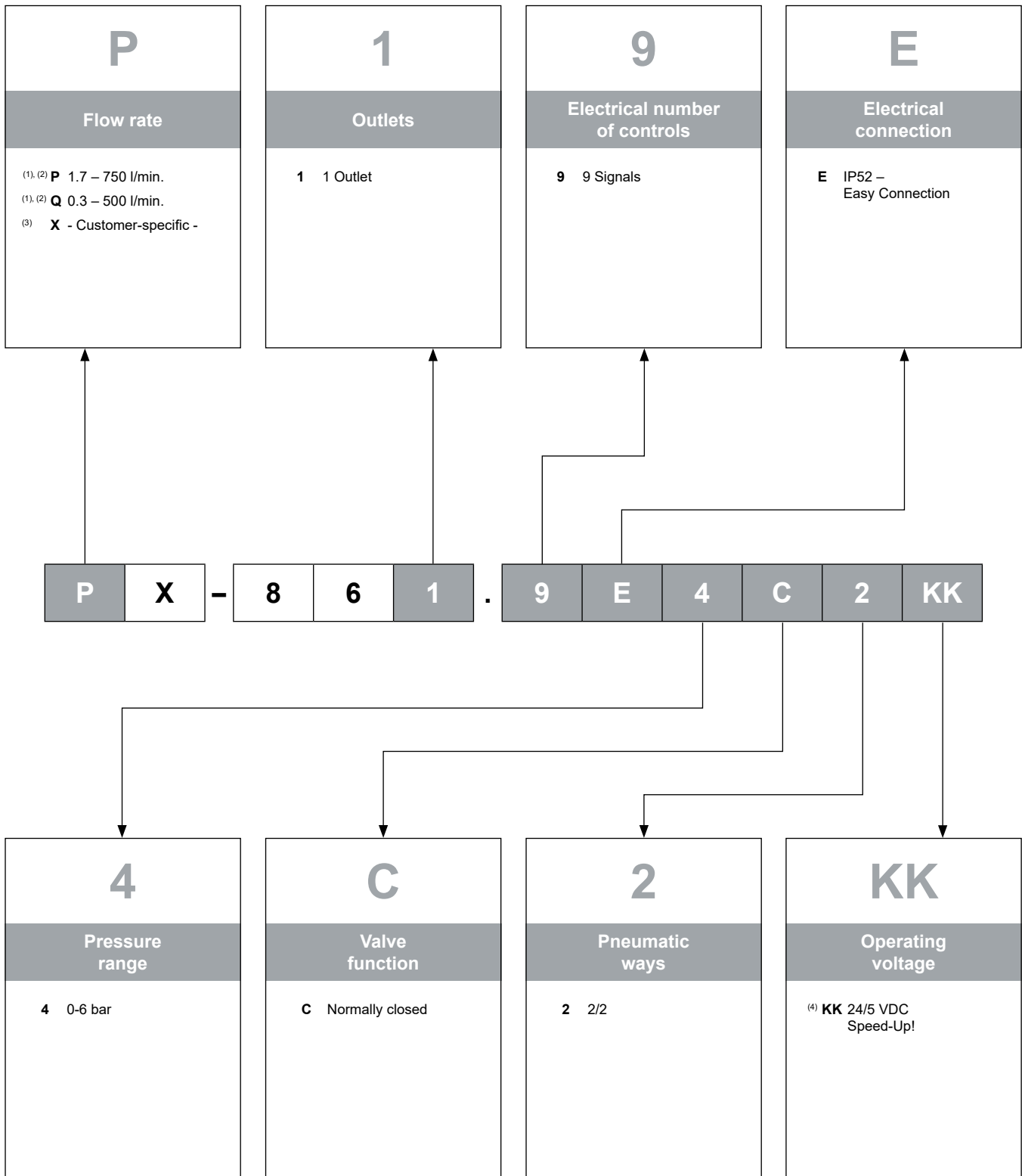

- (1) Among other things the flow rate value is dependent on the supply pressure
- (2) The maximum flow rate refers to 6 bar rel. and completely open valve
- (3) Customer-specific flow rates on request
- (4) Requires a Speed-Up! Control (see intro pages)

Drawings and connections

Type 861

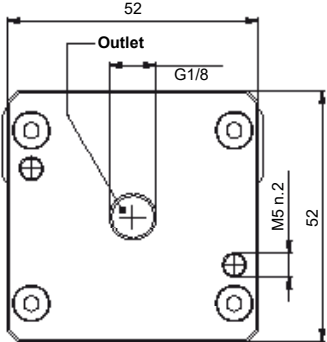
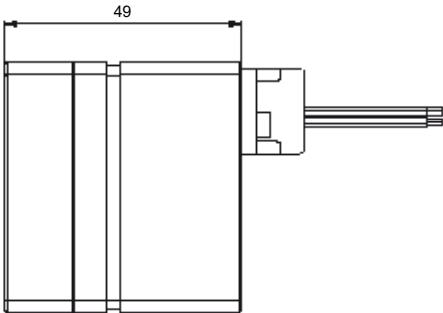
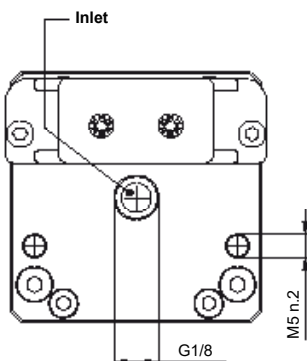
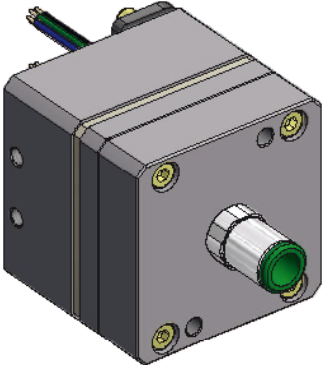

Customer Solutions

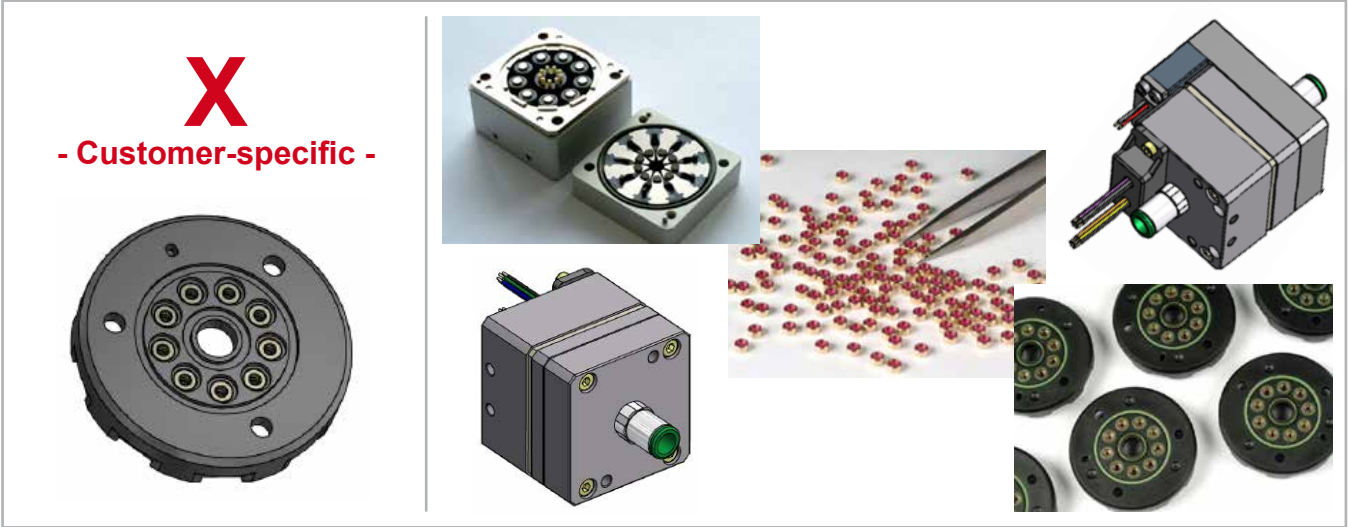

## 880 SERIES

The 880 series is a multi-valve with 2/2 function in NC (normally closed). Two integrated valve rockers in one compact body, combined with the Speed-Up control technique, enable a high flow capacity of 300 l/min., switching times from < 2 ms and a frequency of up to 450 Hz.

Optionally there is a miniature controller, which is integrated directly on the valve. In this version the Speed-Up technology can be operated with a standard 24 V signal without separate requirements or adaptations to existing controllers.

Depending on the version, the two integrated valve rockers can be switched together or separately, in order to switch 50% or 100% of the flow capacity. The 880 series is available as individual valve as well as manifold mounting valve.



### Technical data

	KK	XX	WW
Switching time opening*	< 2 ms		
Switching time closing*	< 2 ms		
Maximum frequency	350 Hz	450 Hz	350 Hz
Weight	from 80 g		
Protection class	IP62 – IP65		

\*Varies with the working pressure

Outlets	1
Flow rate	430 l/min.
Function	2/2 way in NC
Pressure range	between 0-8 bar

### Possible function

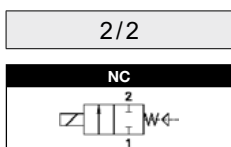

### Possible control

Direct / PWM / PFM / PNM / Combination  
Information, see Page 5

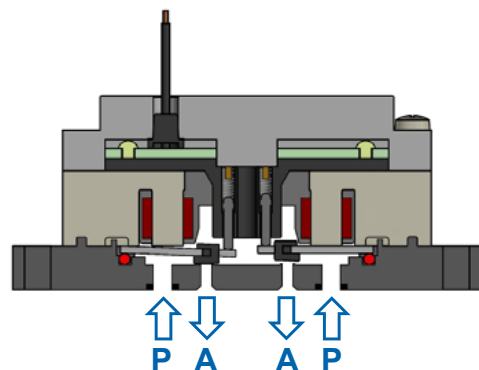

Section: Type 2/2 NC

Ordering code

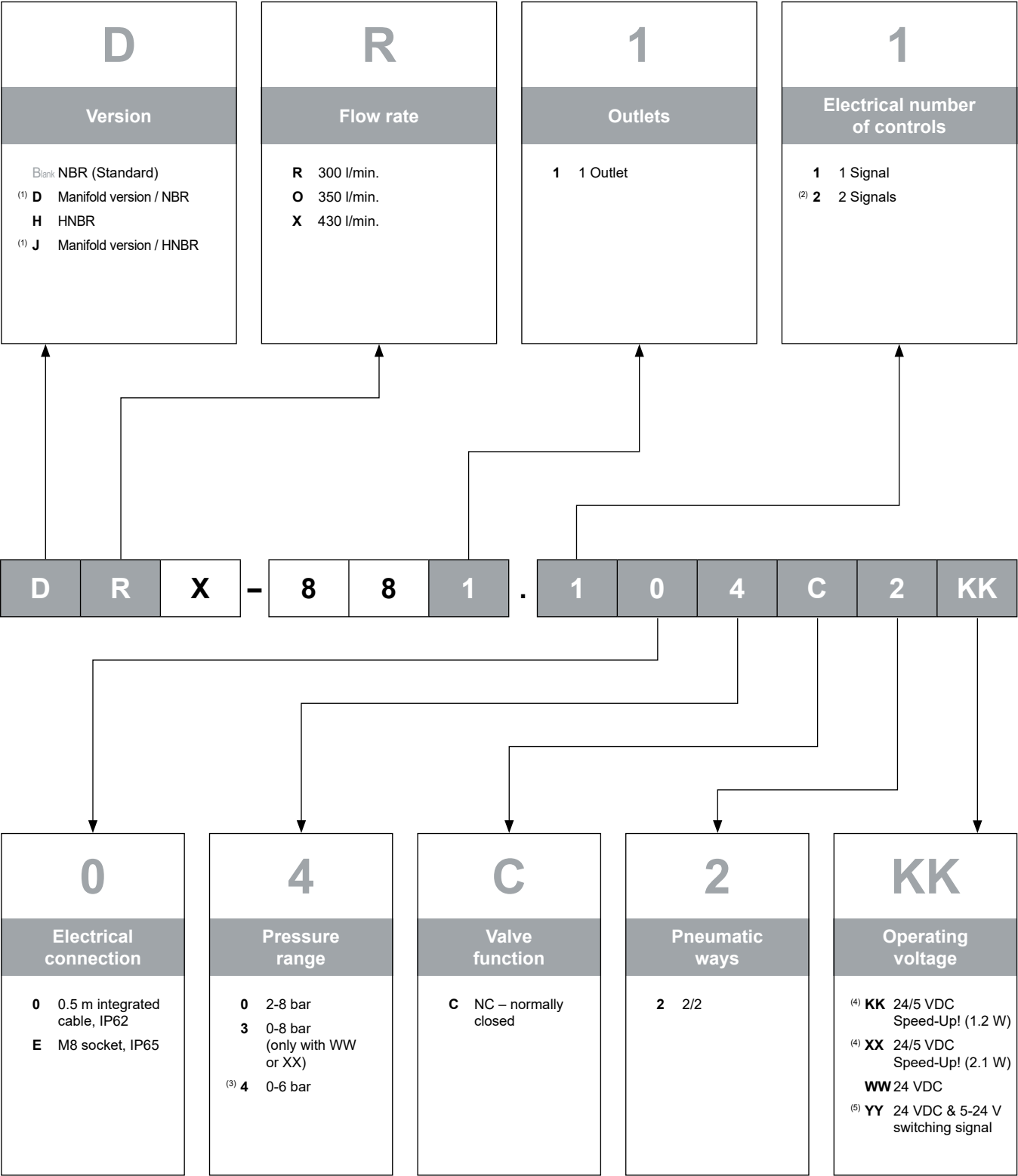

(1) without thread and plug-in connections  
(2) Enables switching of 50 % or 100 % of the flow capacity

(3) Only available with WW or XX voltage  
(4) Requires a Speed-Up! Control (see intro pages)  
(5) 1x 24 VDC supply voltage & 1x 5-24 V switching signal (e.g. PLC)

# 880 SERIES

## Drawings and connections

### Manifold mounting version

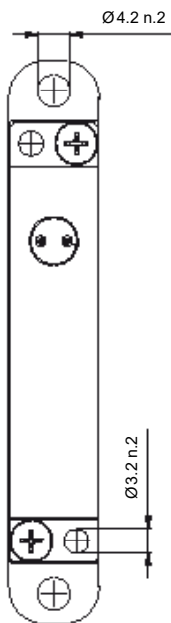
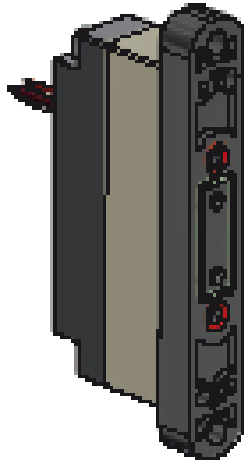

### Standard version

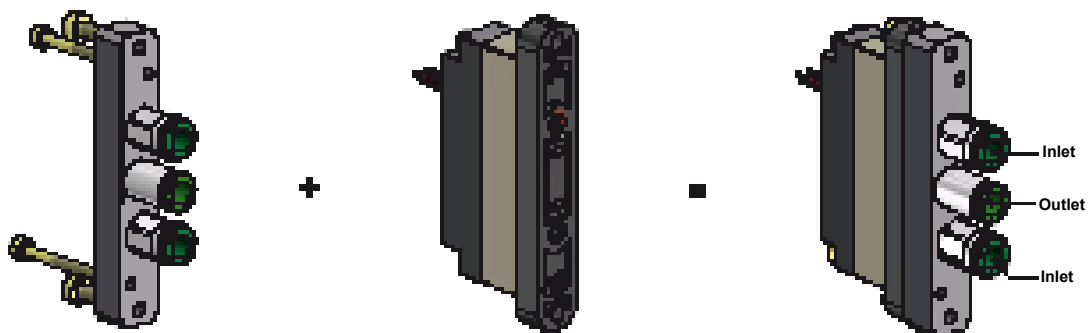
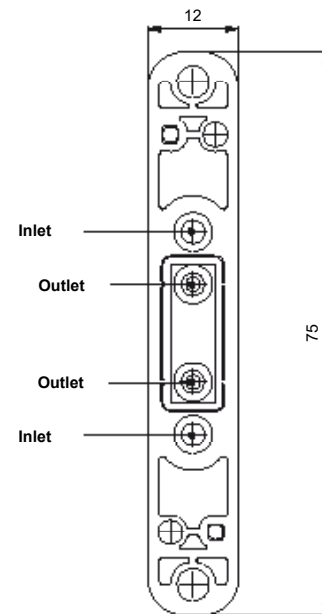
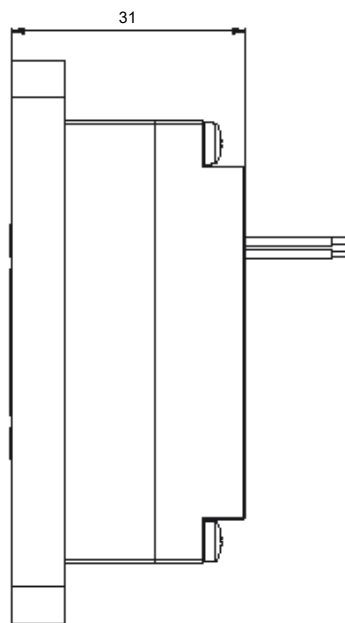
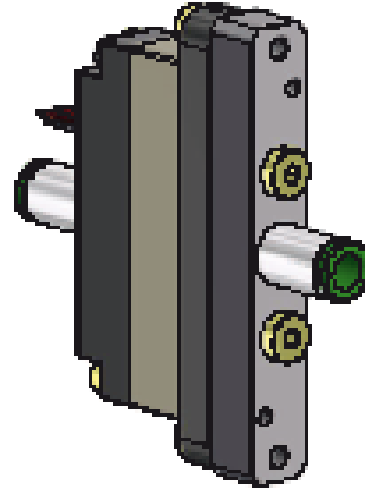



Product examples and special solutions

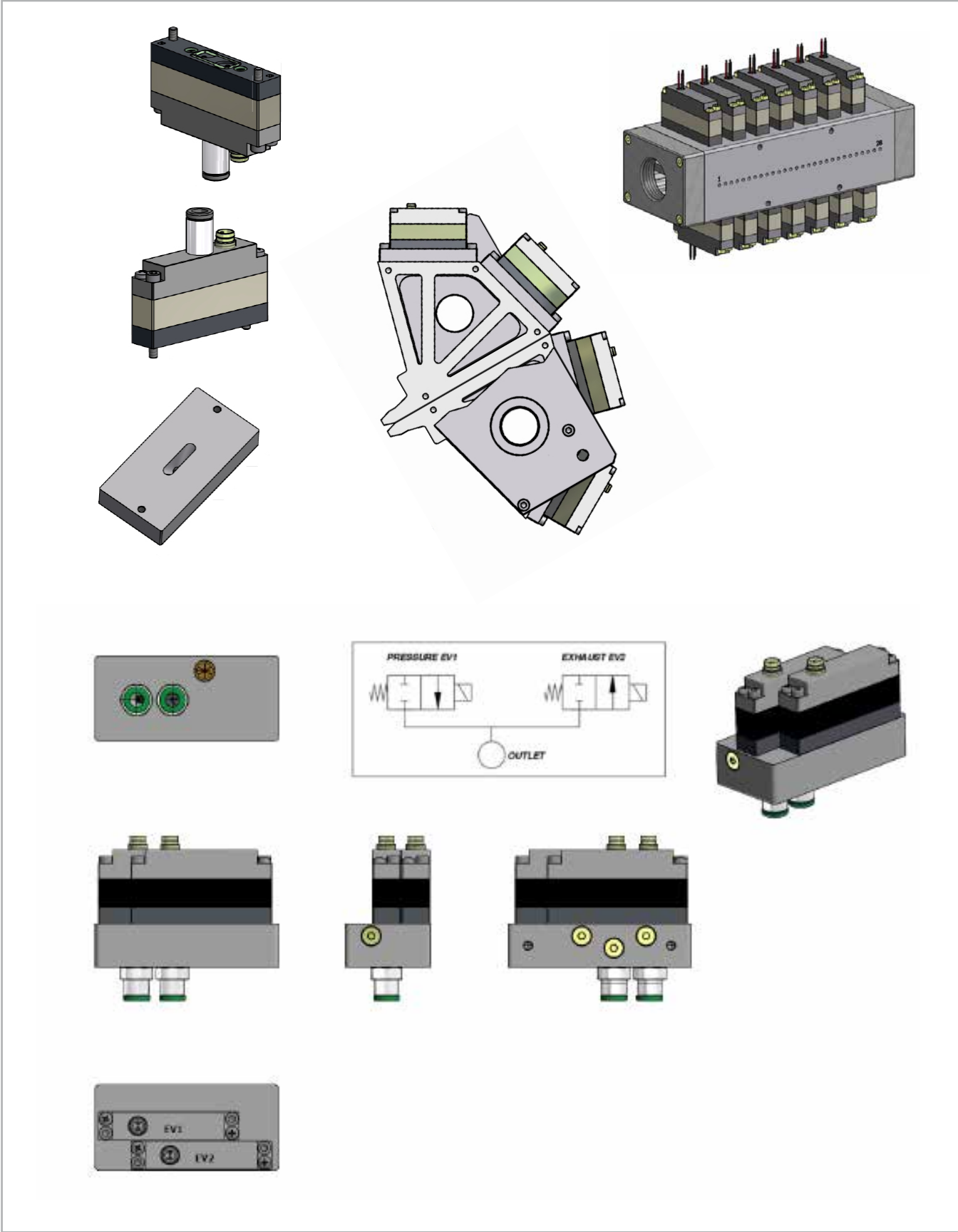

## 890 SERIES

The 890 series is a multi-valve and contains 9 individual valves with 2/2 function in NC (normally closed). Depending on the configuration one achieves a flow capacity of max. 1,530 l/min. and has up to 9 valve outlets which can be switched individually. Due to the modular design, this valve series is also excellently suited as base valve for a wide variety of output requirements. 6 different versions can be created with a mounting kit. This is done by simply changing the outlet flanges and can be carried out by the user. This simplifies e.g. the storage, increases the availability and saves costs.

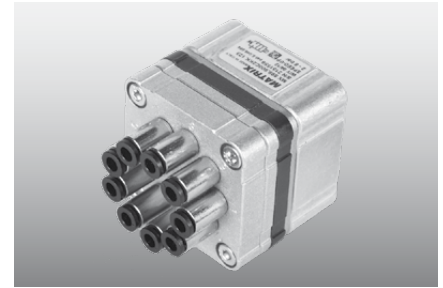

The body has the dimensions of just 46 x 46 x 41.5 mm and has a central air supply. Due to the possibility of a step switch, one can vary the flow rate proportionally and consequently also save enormous energy costs depending on the application.

The Speed-Up version enables a switching time of < 1 ms and a frequency of 500 Hz, which, among other things, effects an extremely high repeat accuracy.

### Technical data

Switching time opening*	24: < 5 ms	KK: < 1 ms
Switching time closing*	24: < 2 ms	KK: < 1 ms
Maximum frequency	140 Hz	500 Hz
Weight	210 g to 320 g	
Protection class	IP62	

\*Varies with the working pressure

Outlets	1, 2, 3, 4 or 9
Flow rate	up to 1,530 l/min.
Function	2/2 way in NC
Pressure range	between 0-8 bar

### Possible function

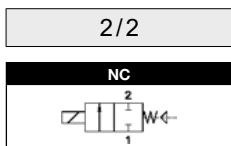

### Possible controls

**Direct / PWM / PFM / PNM / Combination**

*Information, see Page 5*

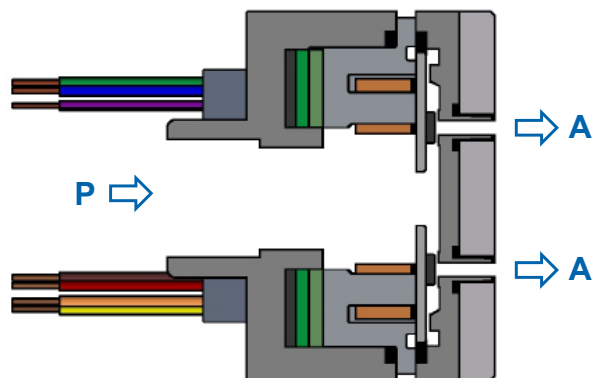

*Section: Type 2/2 NC*

Ordering code

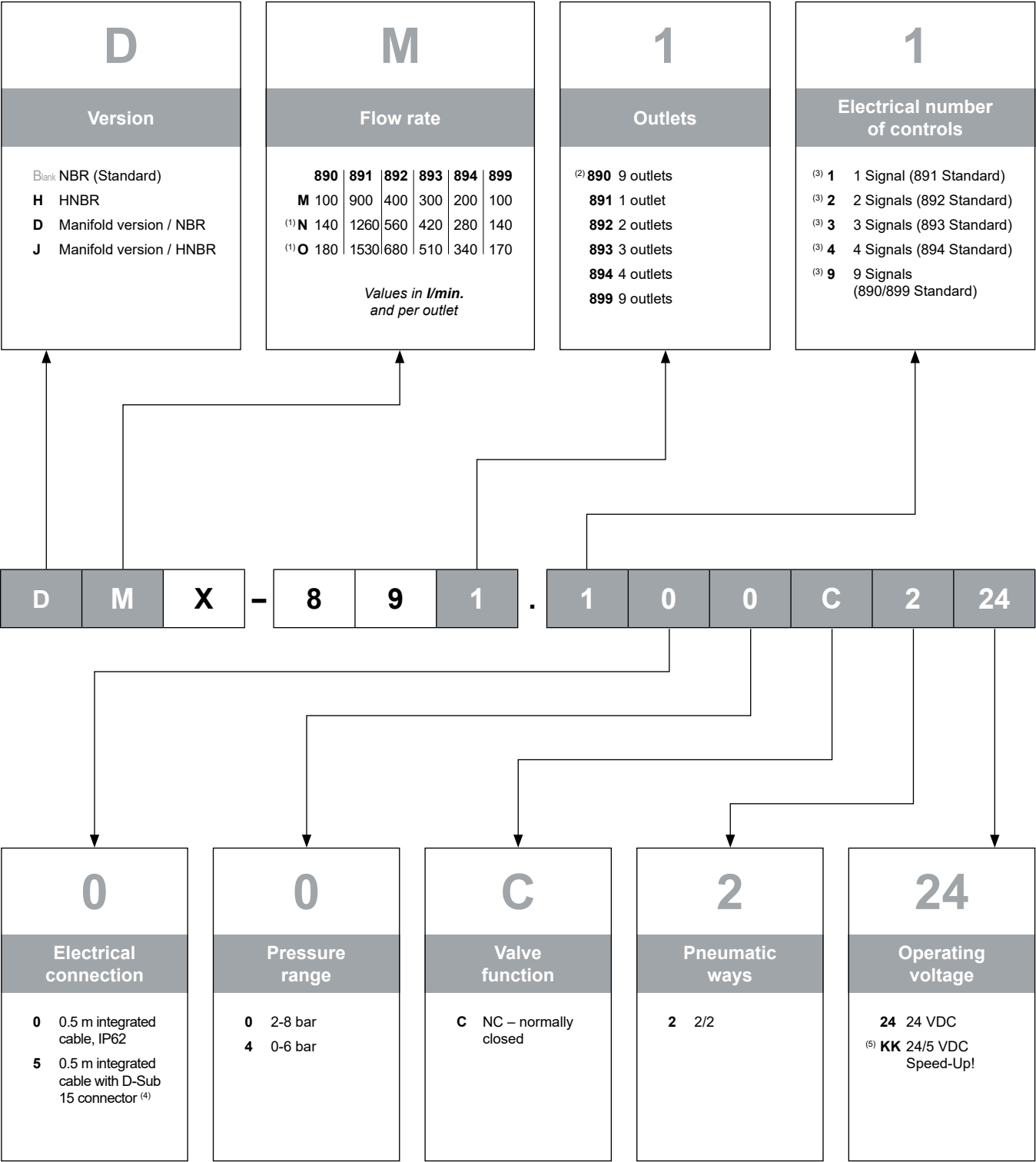

(1) Only available in the operating voltage KK  
 (2) Outlet flange without thread and plug-in connections  
 (3) In the standard every outlet has a signal cable. Optionally one can:  
 • apply 9 signals to one outlet, to achieve a proportional flow rate (e.g. 891.9 = 1 outlet, 9 signals)  
 • switch up to 9 outlets at the same time with one signal (e.g. 899.1 = 9 outlets, 1 signal). Only for version MX or NX.  
 (4) Only available with 9 signals  
 (5) Requires a Speed-Up! Control (see intro pages)

# 890 SERIES

## Drawings and connections

### Manifold mounting version

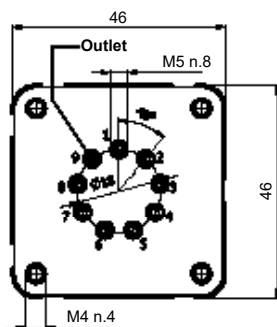
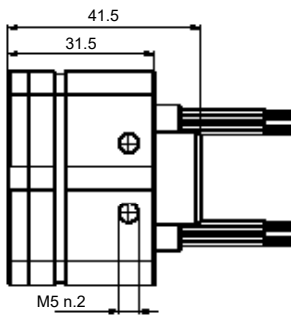
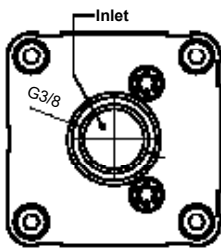
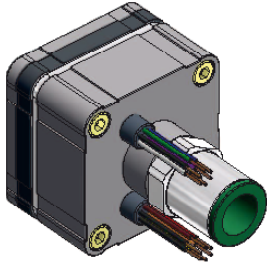

### Manifold mounting version with flange

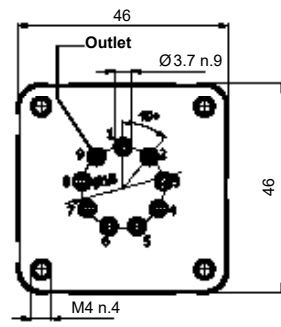
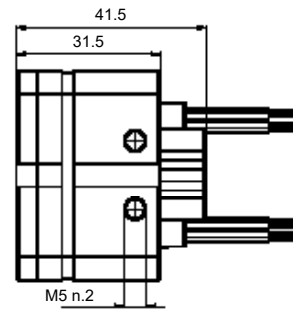
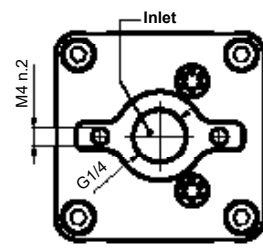
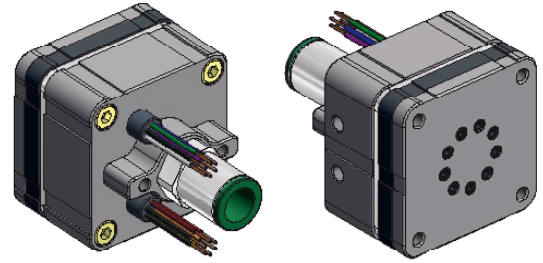

Drawings and connections

Type 891

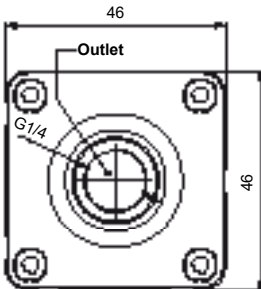
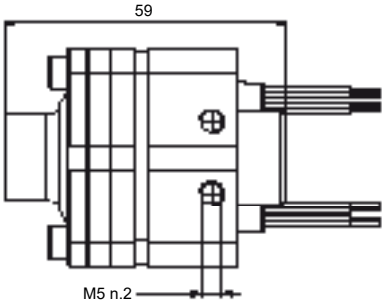
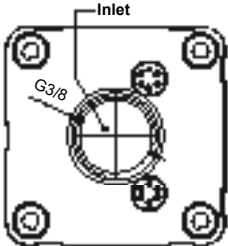
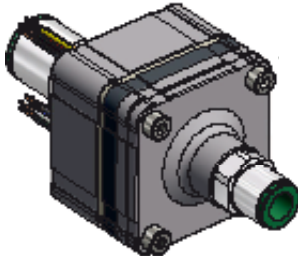

Type 892

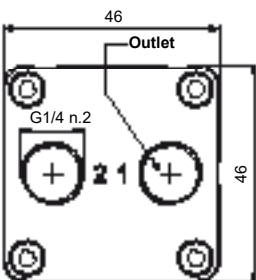
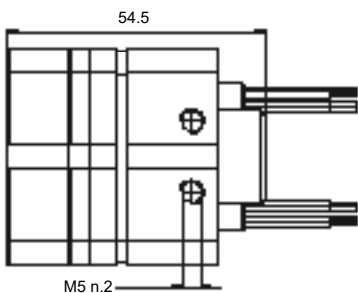
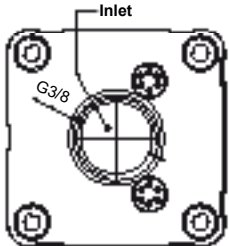
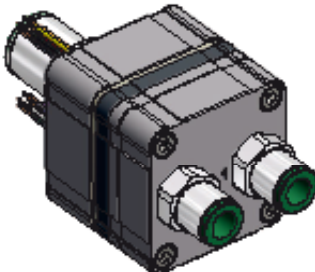

Type 893

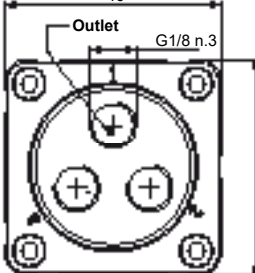
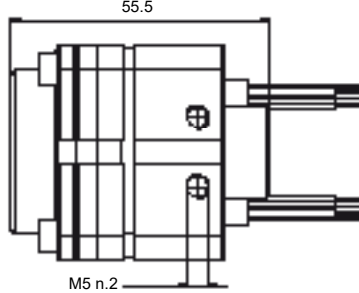
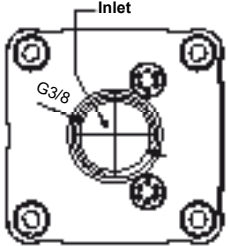
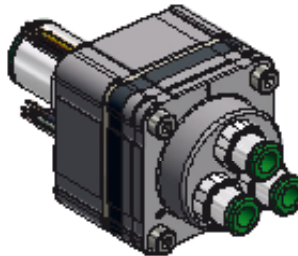

# 890 SERIES

## Drawings and connections

Type 894

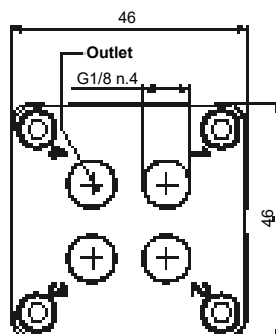
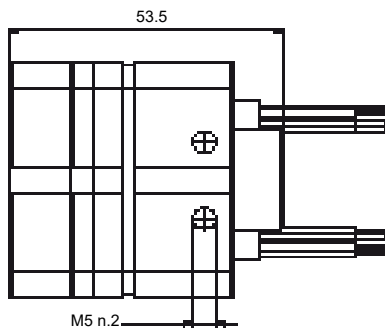
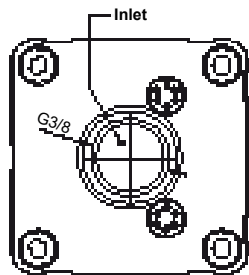
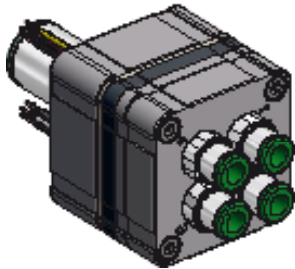

Type 899

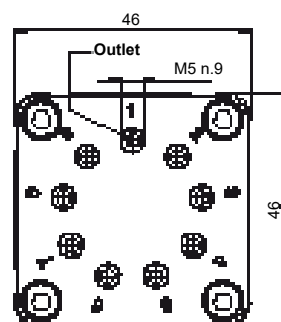
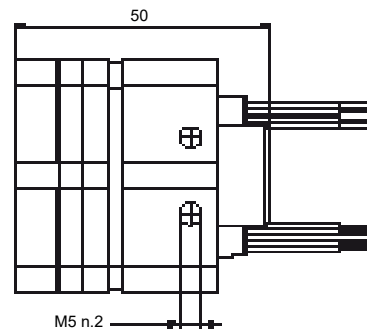
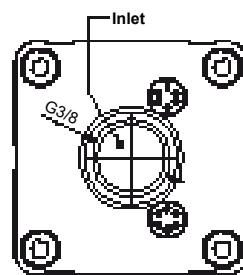
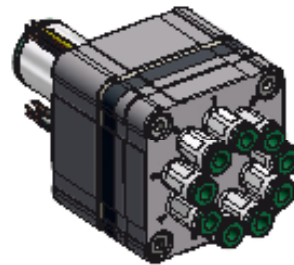

Product examples and special solutions

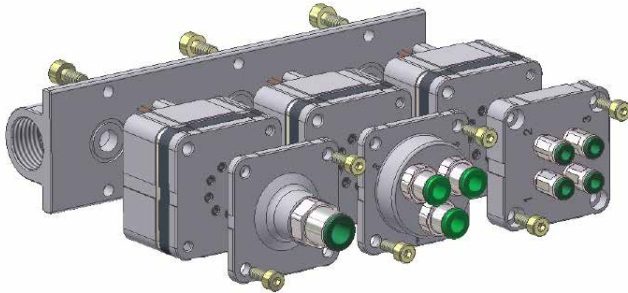
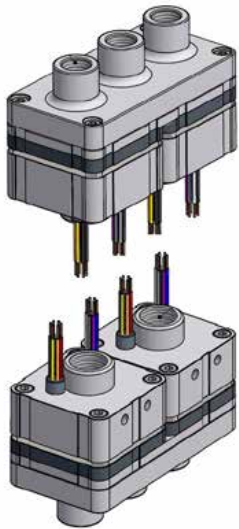
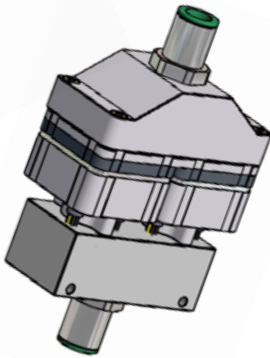
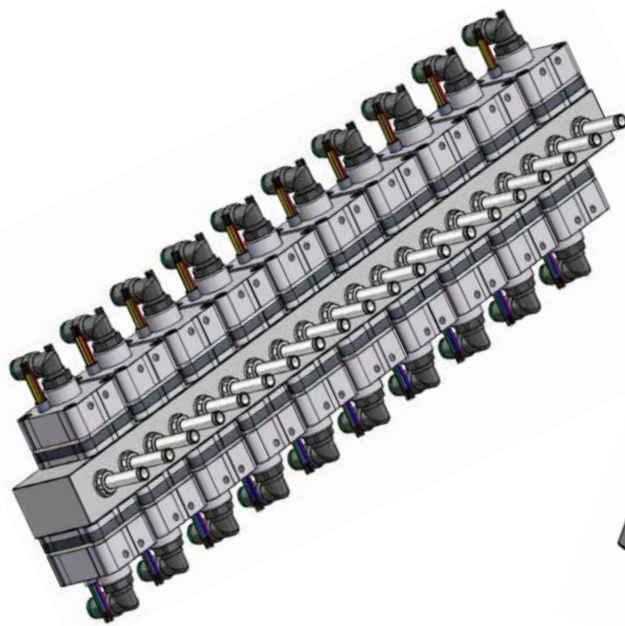
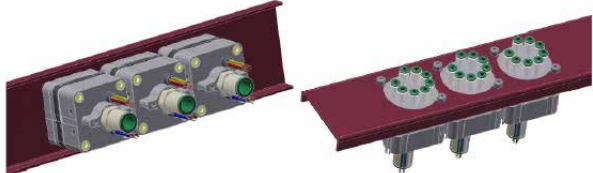
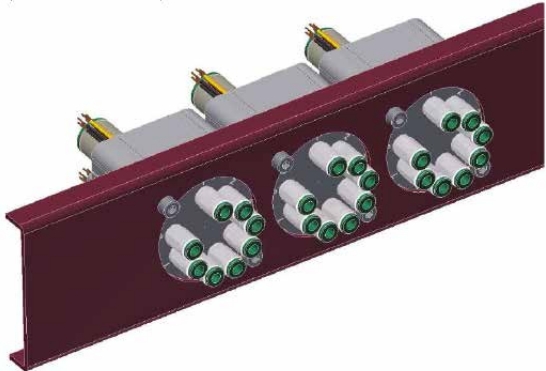



# EPR / SPR SERIES

## Overview MATRIX Pressure Regulators

The EPR and SPR series are compact electronic pressure regulators for the pneumatics with an 8 Bit microprocessor. The control signal can be in the form of voltage or current, per direct input on the keypad of the unit as well as via RS-232.



The MATRIX pressure regulators are available in two basic versions:

**Type A**

Control via voltage signal (V), current signal (mA) or via RS-232

**Type D**

Control via voltage signal (V), current signal (mA), via RS-232 or keypad on the unit including digital display

Depending on the version, D-Sub 15, M12 or DIN 43651 are available as interfaces.

## MATRIX Pressure Regulator EPR100 Series

- Regulating range 0-7 bar
- Flow rate 80 l/min.
- Input signal 0-5 V; 0-10 V; 4-20 mA; RS232
- Interface D-Sub 15
- Optionally with keypad on the unit
- Dimensions 118x70x40 mm
- Weight approx. 0.4 kg



## MATRIX Pressure Regulator EPR 200 / 300 / 500 Series

- Regulating range 0-7 bar
- Flow rate max. 500 l/min.
- Input signal 0-5 V; 0-10 V; 4-20 mA; RS232
- Interface DIN 43651, ISO M12
- Optionally with keypad on the unit
- Dimensions 60x60x97 mm
- Weight approx. 0.5 kg





### MATRIX Pressure Regulator SPR 700 Series

---

- Regulating range 0-10 bar
- Flow rate 1,000 l/min.
- Input signal 0-5 V; 0-10 V; 4-20 mA; RS232
- Interface DIN 43651, ISO M12
- Optionally with keypad on the unit
- Dimensions 60x60x131 mm
- Weight approx. 0.45 kg



### MATRIX Pressure Regulator SPR 900 Series

---

- Regulating range 0-10 bar
- Flow rate 4,000 l/min.
- Input signal 0-5 V; 0-10 V; 4-20 mA; RS232
- Interface DIN 43651, ISO M12
- Optionally with keypad on the unit
- Dimensions 62x62x158 mm
- Weight approx. 0.95 kg



### MATRIX Pressure Regulator SPR 1000 Series

---

- Regulating range 0-7 / 0-12 / 8-14 bar
- Flow rate 5,000 l/min.
- Input signal 0-5 V; 0-10 V; 4-20 mA; RS232
- Interface D-Sub 15 or DIN 43651 socket
- Optionally with keypad on the unit
- Dimensions 70x100x256 mm
- Weight approx. 1.3 kg



**You can gladly receive more detailed information and documentation about the MATRIX pressure regulators on request.**

# SPECIAL SOLUTIONS

From the *Idea*

... to *Prototype*

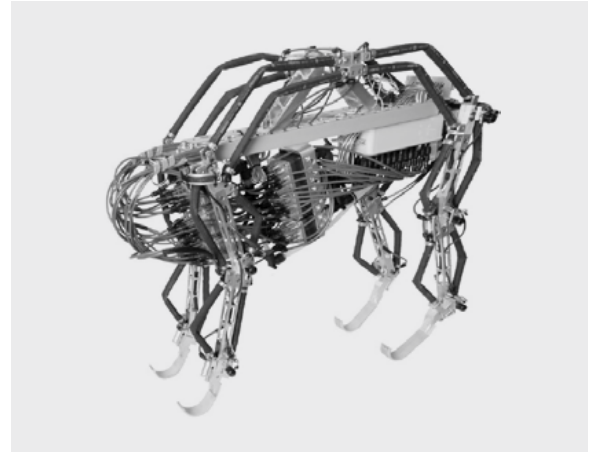

From the *Conception*

... to *Series*

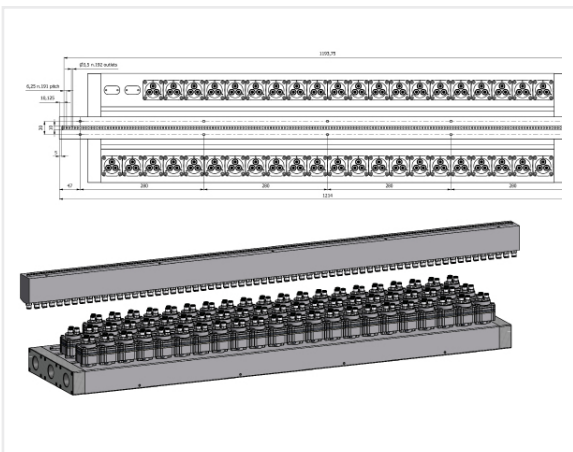

From the *Development*

... to new *Markets*

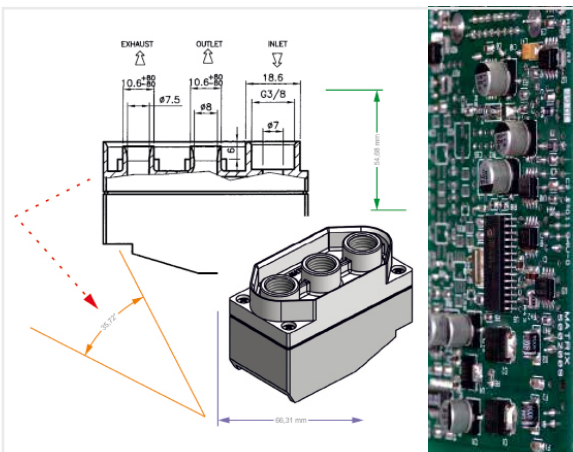

## Modular System

The modular expansion of all MATRIX valve series enables the perfect basis for application-specific adaptations.

- > Change of the position for the inlet/outlet connection
- > Specified flow rate values also for digital control (binary code)
- > Multiple supply of different pressures (e.g. pressure and vacuum)
- > Multiple supply of different media (e.g. doser/mixer of gases)
- > Customer-specific interfaces (mechanical and electrical)

Due to the design, customer solutions are also economically feasible in small batches.



## 890 Series

Versions



### Basis valve 890

The basis of the 890 series is the manifold version with 9x 2/2 NC valves. In combination with the respective outlet flange, the outputs of the individual valves are cumulated. That produces different flow rate values, which, depending on the configuration, can also be regulated proportionally.



Types	891	892	893	894	899
<b>MX</b>	100 ÷ 900	100 ÷ 400	100 ÷ 300	100 ÷ 200	100
<b>NX</b>	140 ÷ 1,260	140 ÷ 560	140 ÷ 420	140 ÷ 280	140
<b>OX</b>	170 ÷ 1,530	170 ÷ 680	170 ÷ 510	170 ÷ 340	170

*Flow rate values per outlet*

This modular system also facilitates storage with higher availability at the same time as well as simplification of the plant control.

## Custom production

Combination examples of 890 series

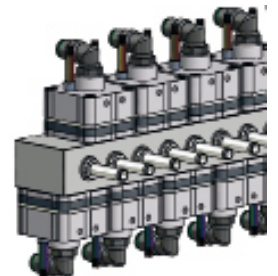
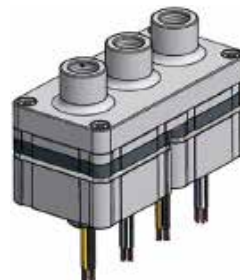
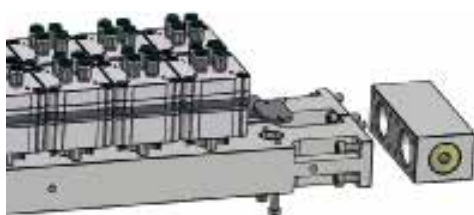

# CUSTOMER- AND BRANCH SOLUTIONS

## Solutions for industry and automation

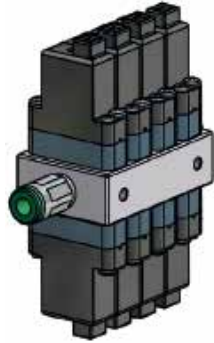

Combination for proportional flow rate

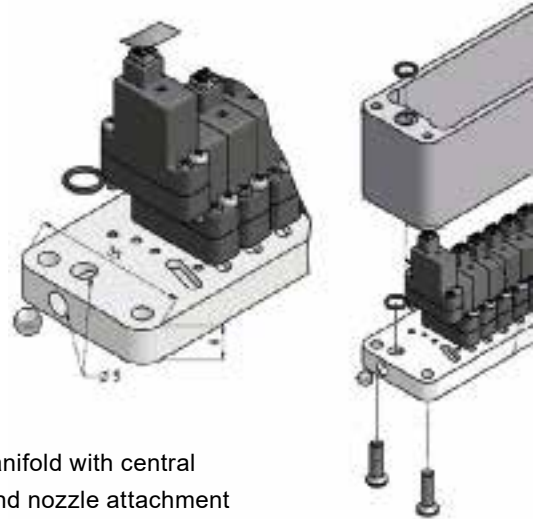

Valve manifold with central supply and nozzle attachment

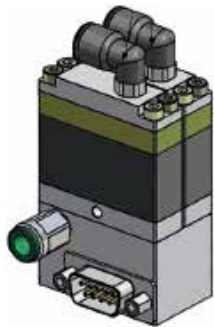

Combination and Sub-D interface



Combination of multi- and individual valves

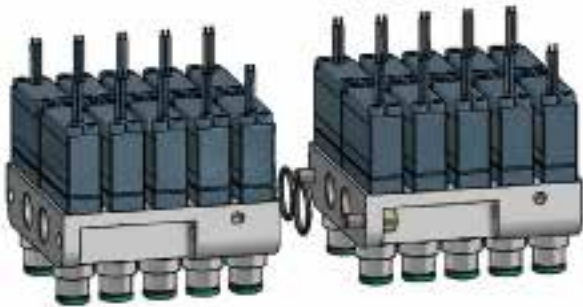

Expandable valve batteries



Multi-valve with customer-specific interface



Modular multi-valves with common supply- and support bar



High-speed valves and nozzle bars for the sorting technology

The patented MATRIX valve technology enables extremely fast switching times, very high frequencies and, with the individual/multi-valve layout, a variety of individual installation arrangements.

Consequently, MATRIX offers a large range of Plug-and-Play products for air ejection systems with the following highlights:

- > Nozzle grids from 2 mm with individual and multifunctional configuration possibilities
- > Switching time of < 1 ms for the 100% opening or closing of the air duct
- > Valve configurations with > 4,000,000,000 switching operations and constant performance
- > Variable flow rate and configurations for maximum flexibility
- > Valve manifolds pre-assembled and 100% tested



Modular system for customer-specific sizes and configuration

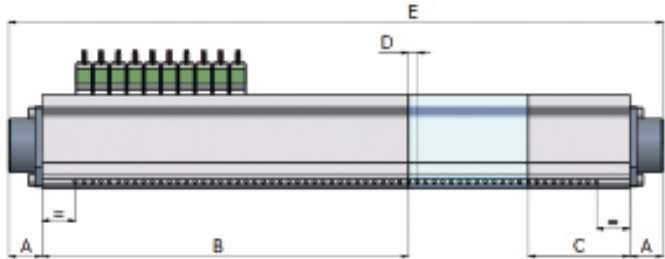
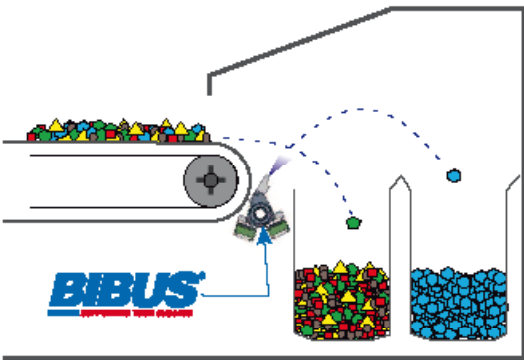

# VALVE MANIFOLDS

Model examples from sorting technology installations

## GS Series

Compact multi-valves with directly mounted nozzle flange

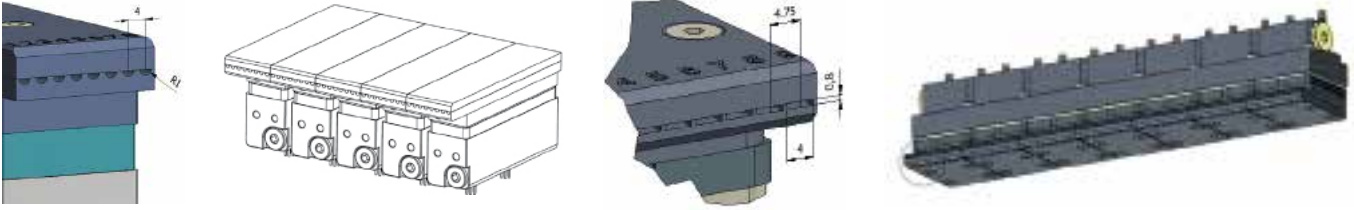

## GM Series

Nozzle bar configurable with individual and multi-valves

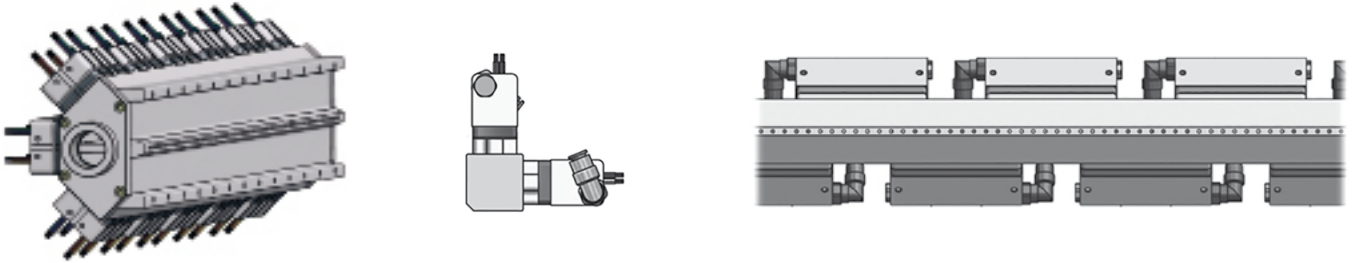

## GMT Series

Twin nozzle bar configurable with individual and multi-valves

TWIN configuration with vertical offset between upper and lower nozzle bar

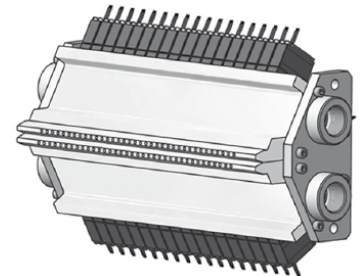

## GMN Series

Combination of individual and multi-valves with nozzle bars

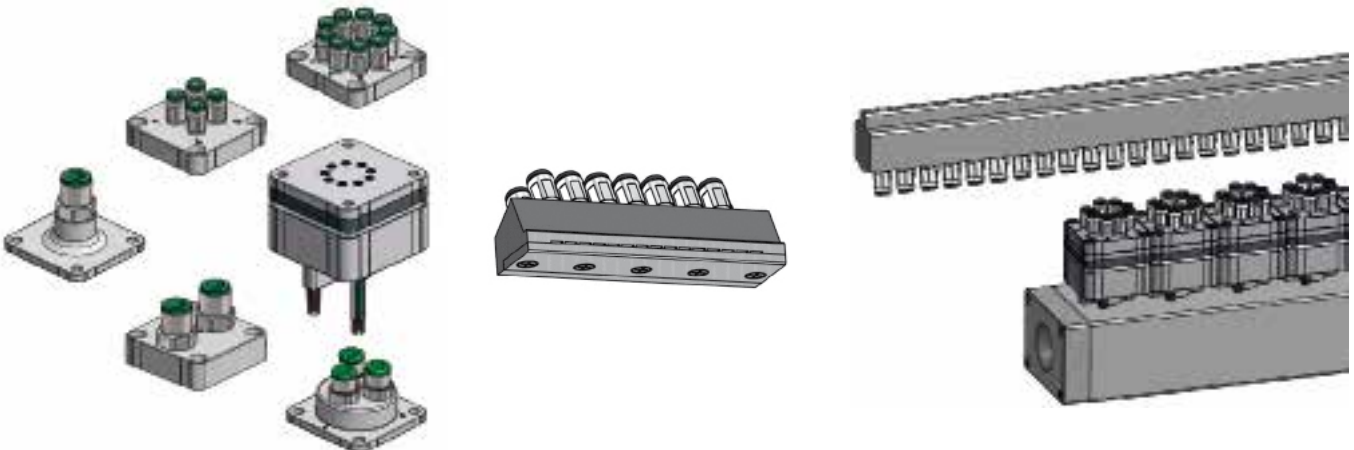

Valves for the medical technology

Respiratory & Bronchial

Regulation and dosing of neutral gases

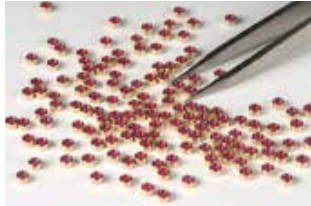

Physiology

Regulation and dosing of neutral gases



Despite the 100% functional test of all MATRIX valves, the products for the medical technology are subjected to additional quality assurance up to and including complete traceability of all installed components. Furthermore, these products are manufactured and customer-specific tested, logged and packed in separate clean rooms.



This high quality assurance permits a Plug-and-Play component for the medical technology.



Note:

The custom solutions shown are merely an extract from our delivery program and possibilities. Please contact us and we will gladly check our possibilities for your requirements.



ENGINEERING  
LOGISTICS  
SERVICES

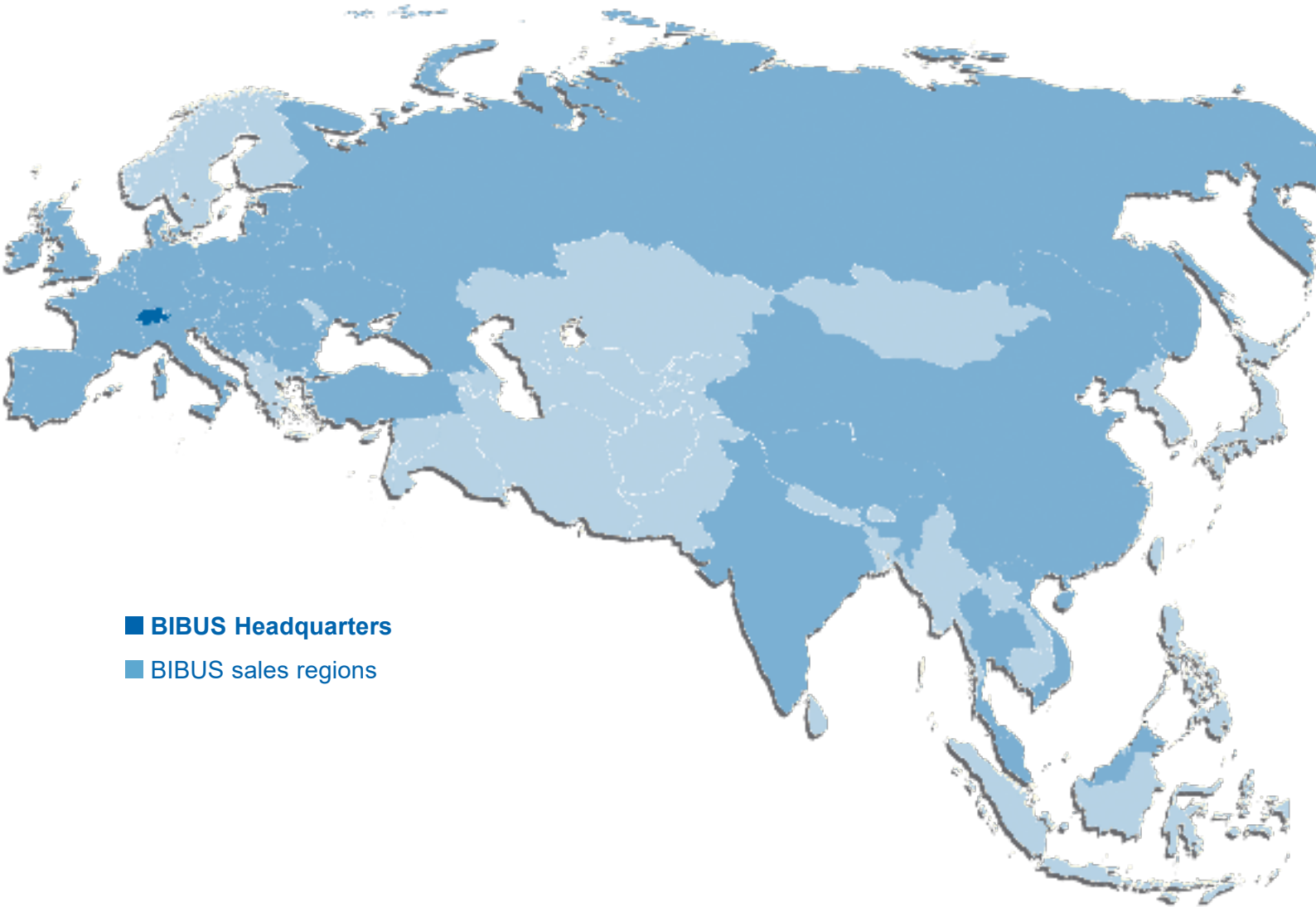

- **BIBUS Headquarters**
- **BIBUS sales regions**

**BIBUS (UK) Ltd**  
20-21 Soho Mills,  
Wooburn Green,  
Bucks, HP10 0PF  
Phone: 01628 533300  
Email: [info@bibus.uk](mailto:info@bibus.uk)  
[www.bibus.uk](http://www.bibus.uk)